

AN 2000 C Load Monitor/ Signal Conditioner/Display

FEATURES

- 1 to 4 Transducer Power Supplies: 5 V or 10 V / 120 mADC
- 5 Red Digits (± 32000), 14 mm Height, 96 x 48 mm Format
- 16 Acquisitions per Second
- Logic Inputs for Remote Functions
- Hold, Tare, Peak and Valley Functions
- Panel or DIN Rail Mounting
- IP 65 Front Panel (indoor use)
- 1 to 3 Flexible Configurations with Interchangeable Options:
 - 2 or 4 thresholds (relays)
 - 0–10 V / 4–20 mA analog output
 - RS-232C or RS-485 serial output
- Programmable with Front-Panel Keys
- Quick Wiring Using WAGO Connectors



OPTIONS

- Relay Outputs (thresholds): 2 SPDT or 4SPST
- Analog Output: 0-10 V or 4-20 mA
- Serial Output: RS-232C or RS-485

DESCRIPTION

The AN 2000 C Load Monitor is designed to process and display signals coming from various types of transducers (weight, load, pressure, torque, etc.) that use standard strain-gauge bridges. It can also receive any signal within the range ± 300 mVDC coming from a shunt, a converter or any type of transmitter.

The monitor provides selectable input ranges (15 mV, 30 mV, 60 mV or 300 mV) and excitation voltages (5 V or 10 V) to accommodate cells of various types and sensitivities. Two programming methods allow scaling the meter to operate in the desired engineering units.

The basic instrument consists of a PCB assembly including the main board, the display and the power supply filter, to which the A/D conversion circuit and the input option are added. The latter two elements are connected by their own connectors.

The AN 2000 C is used with Magtrol Load Measuring Pins to measure load and force and provide overload protection. Magtrol also offers a wide range of Load-Force-Weight Transducers in various executions and accuracy classes and our Load Monitoring Units (LMUs) constitute an ideal safe measurement system which continuously checks for short-circuits and interrupted signal lines.

The functions of the basic instrument include the display of the input variable as well as the remote freezing of the display (HOLD), the reading of the stored minimum and maximum values (PEAK & VALLEY) and the TARE function with reset to zero.

SYSTEM CONFIGURATION

**AN 2000 C Load Monitor/
Signal Conditioner/Display**

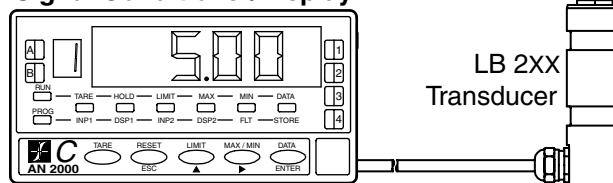

MEASUREMENT CHARACTERISTICS						
Transducer Power Supply	5 V or 10 V; 120 mA					
Signal Processing	Asymmetrical differential					
• Type	16 conversions/second					
• Conversion Speed	± 16 bits					
• Conversion Definition	4 Hz to 0.05 Hz					
• Response Delay (P filter)	14 to 37 dB/10					
• Cut-off Frequency	10 levels					
• Slope						
• Input Damping (E filter)						
Input	±300 mV					
• Maximum Value	0.5 µA					
• Resolution	100 MΩ					
• Input Impedance						
Measurement Display	7-segment alphanumeric display					
• Type	±32000					
• Display Definition	5 digits / 14 mm high (≈0.55 in.) / red					
• Digits / Dimension / Color	62 ms					
• Display Refresh Rate	programmable					
• Decimal Point						
Accuracy	± (0.1% of the reading + 2 count)					
• Maximum Error	100 ppm/°C					
• Temperature Coefficient	5 min					
• Warm-Up Time						
Overrange Indication	0UFLo					
OPERATING INDICATIONS (LEDs)						
RUN / PRG mode	2 green / orange LEDs					
Thresholds 1, 2, 3 and 4	4 red LEDs					
Indication Colors (6 LEDs)	orange	yellow	red	orange	yellow	green
• Control Indication	TARE	HOLD	LIMIT	MAX	MIN	DATA
• Programming Indication	INP 1	DSP 1	INP 2	DSP 2	FLT	STORE
Display of Program Steps	one 7-segment green LED					
KEYBOARD						
Operating Keys	TARE, RESET, LIMIT, MAX/MIN, DATA					
Programming Keys	TEACH, ESC, ▲ , ► ENTER					
PROGRAMMING						
5 Program Menus	1) Input configuration					C N I N P
	2) Display configuration					C N d S P
	3) Setpoint input					C N d S P
	4) Analog output configuration					C N d S P
	5) Serial RS-output configuration					C N d S P
POWER SUPPLY						
AC	115 VAC; 50/60 Hz ±10%					
	230 VAC; 50/60 Hz ±10%					
	48 to 24 VAC; 50/60 Hz ±10%					
DC	10 to 30 VDC isolated					
ENVIRONMENTAL AND MECHANICAL CHARACTERISTICS						
Operating Temperature	-10°C to +60°C					
Storage Temperature	-25°C to +80°C					
Relative Humidity, Non-Condensing	<95% at 40°C					
Protection Class	IP 65 front panel; IP 45 housing					
Housing Material	UL 94V-0 polycarbonate					
Weight	600 g (1.32 lb)					

DIMENSIONS

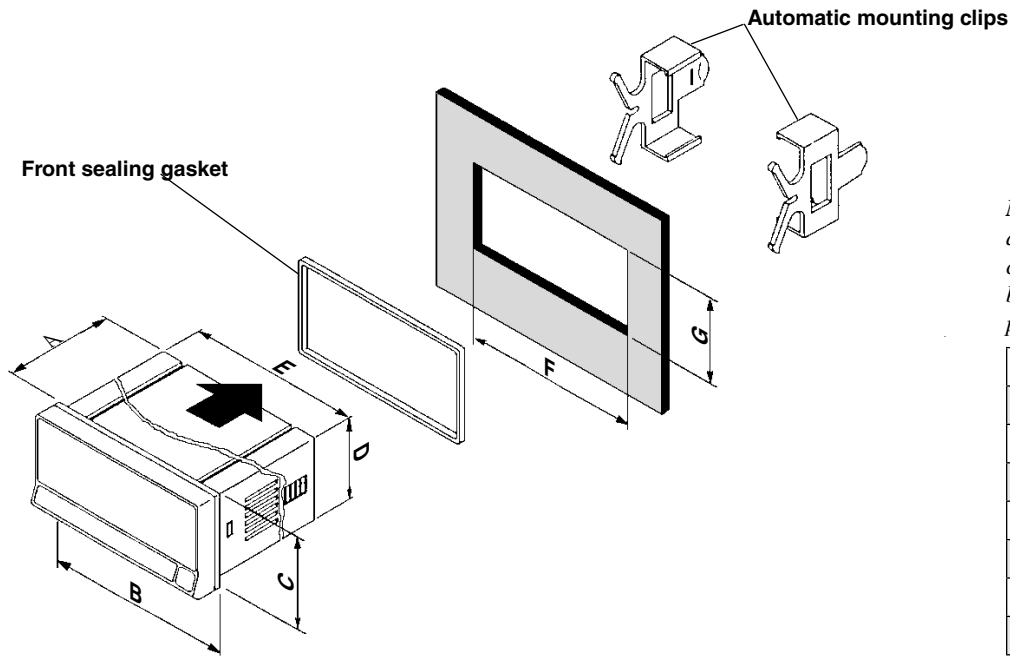

ASSEMBLY OVERVIEW

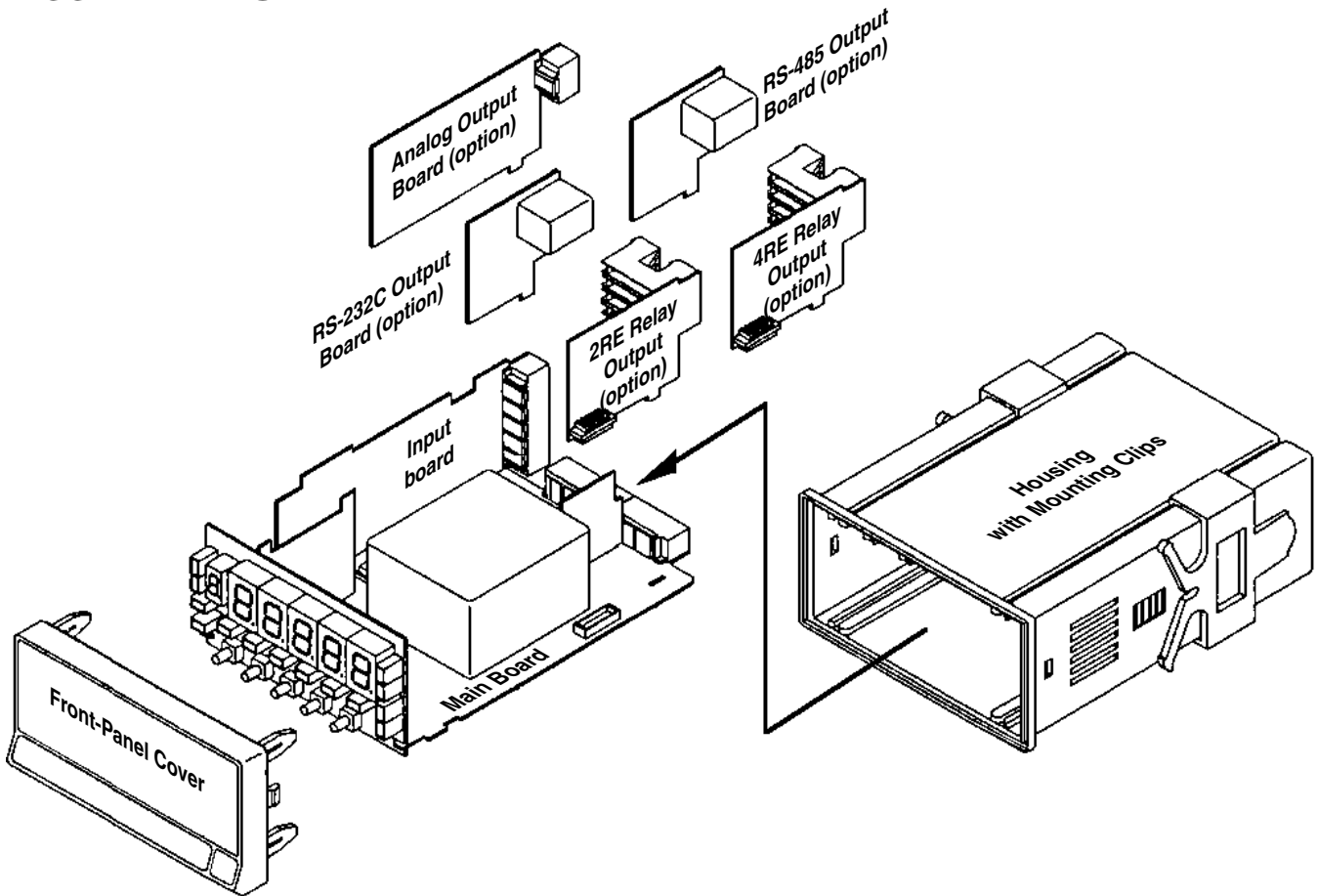

CONTROL OPTIONS

Relay Output Boards (2RE and 4RE)

Characteristics	2 Threshold Values (2RE)	4 Threshold Values (4RE)
Number of Thresholds	2	4
Switching Capacity	8 A / 250 VAC	0.2 A / 250 VAC
Maximum Power	2000 VA / 192 W	25 VA / 10 W
Function	SPDT Single Pole Dual Toggle	SPST Single Pole Single Toggle (1 common for 4 relays)
Response Time	10 ms	6 ms
Programming	±32000	
Coupling	Independence and association 1-2 and 3-4	
Activation Mode	< or >	
Programmable Delay	0 to 999.9 s	
Programmable Asymmetrical Hysteresis	0 to 32000	
Programmable Symmetrical Hysteresis	0 to 32000	
Weight	≈40 g / ≈1.41 oz	

NOTE: The 2RE and 4RE output boards cannot be installed simultaneously in the monitor.

Analog Output Board (ANA)

Characteristics	0-10 V Output	4-20 mA Output
Resolution	12 bits / 0.1% FSD ±1 bit	
Response Time	60 ms	
Temperature Drift	0.2 mV/°C	0.5 µA/°C
Maximum Load	≥ 500 Ω	≤ 800 Ω
Weight	≈20 g / ≈0.71 oz	

This board is used to transmit displayed values (full or partial measuring range) by means of a 0-10 V or 4-20 mA isolated analog signal.

COMMUNICATION OPTIONS

Serial Output Boards (RS2 & RS4)

Characteristics	RS-232C Board (RS2)	RS-485 Board (RS4)
Baud Rate	1200, 2400, 4800, 9600, 19200	
Protocol	Standard, ISO 1745 or MODBUS	
Address	00 to 99	
Reading Functions of Displayed and Memorized Values	Valley, Peak, Tare, Measure, Thresholds 1 to 4	
Changing of Threshold Values	Thresholds 1 to 4 Digital indication of the threshold value	
Remote Controls (Reset)	Valley, Peak, Set Tare, Clear Tare	
Software Transfer	Only with ISO 1745 protocol	
Weight	≈45 g / ≈1.59 oz	

The RS2 and RS4 output boards allow serial communication with a personal computer or any other unit using a serial RS-232C or RS-485 transmission protocol, respectively. Both boards are also compatible with various graphic display and data acquisition software programs.

NOTE: The RS2 and RS4 output boards cannot be installed simultaneously in the monitor.

NOTE: All outputs are opto-insulated with regard to the input signal.

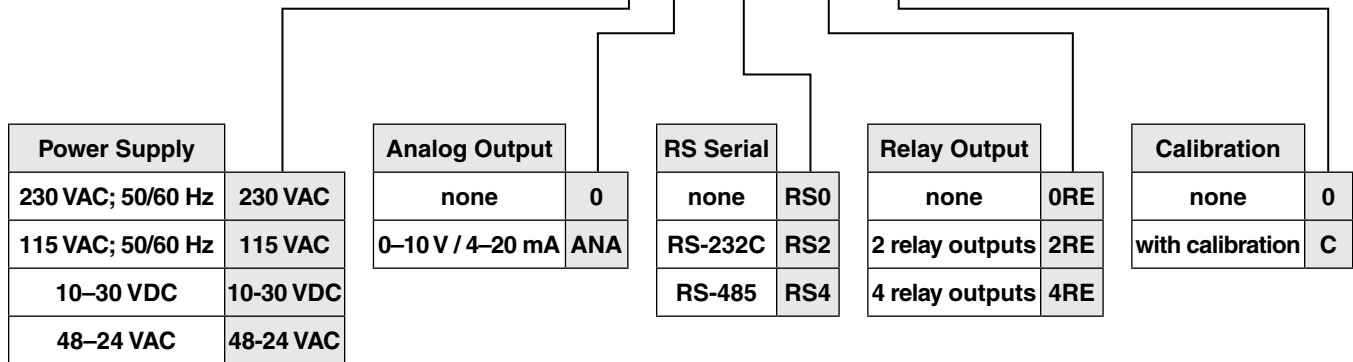
ORDERING INFORMATION
Part Number:
AN 2000C / X / X / RSX / XRE / X

Example: An AN 2000 C with 230 VAC / 50/60 Hz power supply, analog output, RS-232C serial, 4 relay outputs and calibration would be ordered as part number / AN 2000C / 230 VAC / ANA / RS2 / 4RE / C .

Due to the continual development of our products, we reserve the right to modify specifications without forewarning.

www.magtrol.com

MAGTROL INC
 70 Gardenville Parkway
 Buffalo, New York 14224 USA
 Phone: +1 716 668 5555
 Fax: +1 716 668 8705
 E-mail: magtrol@magtrol.com

MAGTROL SA
 Centre technologique Montena
 1728 Rossens/Fribourg, Switzerland
 Phone: +41 (0)26 407 3000
 Fax: +41 (0)26 407 3001
 E-mail: magtrol@magtrol.ch

Subsidiaries in:
 Great Britain
 Germany • France
 China • India
**Worldwide Network
 of Sales Agents**

