HD Hysteresis Dynamometers

ED Engine Dynamometers

HD FEATURES

- 16 Standard Models with Maximum Torque from 2.5 oz-in to 500 lb-in (18 mN·m to 56.5 N·m)
- Hysteresis Braking System: provides precise torque loading independent of shaft speed
- Motor Testing: from no load to locked rotor
- Standard Torque Units: English, Metric and SI
- Accuracy: $\pm 0.25\%$ to $\pm 0.5\%$ (full scale)
- Air Flow Sensor: For protection against overheating and operator error
- Base Plates: available in long or short versions
- Custom Dynamometers: for special torque and speed requirements
- Easy Calibration

HD DESCRIPTION

Hysteresis Brake Dynamometers (HD Series) are versatile and ideal for testing in the low to medium power range (maximum 14 kW intermittent duty). With a Hysteresis Braking system, the Dynamometers do not require speed to create torque, and therefore can provide a full motor ramp from free-run to locked rotor. Brake cooling is provided by convection (no external source), by compressed air or by dedicated blower, depending on the model. All Magtrol Hysteresis Dynamometers have accuracy ratings of $\pm 0.25\%$ to $\pm 0.5\%$ full scale—depending on size and system configuration.

To better integrate dynamometers into systems, Magtrol offers both long and short base plates. The shorter base plate facilitates easier motor mounting when used with T-slot tables and Magtrol Adjustable Motor Fixtures, whereas the long base plates are better suited for table top testing.

HD APPLICATIONS

Magtrol motor test systems can be found in test labs, at inspection stations, and on the manufacturing floors of most of the world's leading manufacturers, users and certifiers of small to medium sized electric, pneumatic and hydraulic motors, as well as internal combustion engines. Magtrol supplies motor test systems for a wide array of industries including: Appliance, Automotive, Aviation, Computer, HVAC, Lawn and Garden, Medical and Dental, Electric Motor, Office Equipment and Power Tools.

ED FEATURES

- Maximum Torque: from 55 lb-in to 250 lb-in (6.5 N·m to 28 N·m)
- Hysteresis Braking System
- Motor Testing: from no load to locked rotor
- Standard Torque Units: English, Metric & SI available
- Accuracy: $\pm 0.25\%$ (full scale)
- Blower Cooled: to maximize heat dissipation
- Air Flow Sensor: for protection against overheating and operator error
- Specially Reinforced Load Cell: stainless steel pin at contact point prevents premature wear from excess vibration
- Larger Shaft: for additional strength
- Gusseted Pillow Blocks: for additional front and rear support
- Easy Calibration

ED DESCRIPTION

With Magtrol's Engine Dynamometers, high performance motor testing is available to manufacturers and users of small engines. Magtrol's Engine Dynamometers have been designed to address the severe, high vibration conditions inherent in internal combustion engine testing.

Magtrol's Engine Dynamometers are highly accurate ($\pm 0.25\%$ of full scale) and can be controlled either manually or via a PC based Controller. For a small engine test stand, Magtrol offers a full line of controllers, readouts and software.

As with all Magtrol Hysteresis Dynamometers, engine loading is provided by Magtrol's Hysteresis Brake, which provides: torque independent of speed, including full load at 0 rpm; excellent repeatability; frictionless torque with no wearing parts (other than bearings); and long operating life with low maintenance. Magtrol provides a NIST traceable certificate of calibration, and calibration beam with each Engine Dynamometer.

ED APPLICATIONS

The Engine Dynamometers are ideally suited for emissions testing as set forth in CARB and EPA Clean Air Regulations. The Dynamometers will offer superior performance on the production line, at incoming inspection or in the R&D lab.

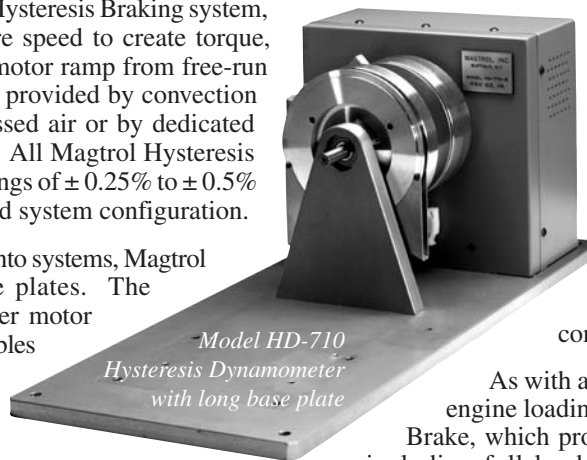

OPERATING PRINCIPLES

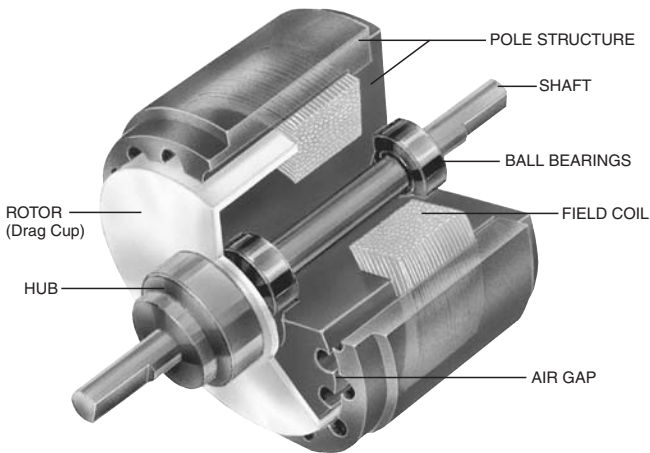

Magtrol Hysteresis Dynamometers absorb power with a unique Hysteresis Braking System which provides frictionless torque loading independent of shaft speed. The Hysteresis Brake provides torque by the use of two basic components—a reticulated pole structure and a specialty steel rotor/shaft assembly—fitted together but not in physical contact. Until the pole structure is energized, the drag cup can spin freely on its shaft bearings. When a magnetizing force from the field coil is applied to the pole structure, the air gap becomes a flux field and the rotor is magnetically restrained, providing a braking action between the pole structure and rotor.

COMPLETE PC CONTROL

Magtrol’s M-TEST 5.0 Software is a state-of-the-art motor testing program for Windows®-based data acquisition. Used with a Magtrol Programmable Dynamometer Controller, Magtrol M-TEST 5.0 Software provides the control of any Magtrol Dynamometer and runs test sequences in a manner best suited to the overall accuracy and efficiency of the Magtrol Motor Test System. The data that is generated by Magtrol’s Motor Testing Software can be stored, displayed and printed in tabular or graphic formats, and can be easily imported into a spreadsheet.

Written in LabVIEW™, M-TEST 5.0 has the flexibility to test a majority of motor types in a variety of ways. Because of LabVIEW’s versatility, obtaining data from other sources (e.g. thermocouples), controlling motor power and providing audio/visual indicators is relatively easy.

Magtrol’s M-TEST 5.0 Software is ideal for simulating loads, cycling the unit under test and motor ramping. Because it is easy to gather data and duplicate tests, the software is ideal for use in engineering labs. Tests can be programmed to run on their own and saved for future use allowing for valuable time savings in production testing and incoming/outgoing inspection.

Magtrol offers three types of dynamometer brakes to absorb load: Hysteresis, Eddy Current and Magnetic Powder. Each type of Dynamometer has advantages and limitations and choosing the correct one will depend largely on the type of testing to be performed. With over 50 models to choose from, Magtrol Sales professionals are readily available to assist in selecting the proper Dynamometer to meet your testing needs.

DYNAMOMETER SELECTION

Magtrol’s Hysteresis Dynamometers cover a wide range of Torque, Speed and Mechanical Power ratings. To select the appropriate size Dynamometer for your motor testing needs, you will need to determine the **Maximum Torque, Speed and Power** applied to the Dynamometer.

Maximum Torque

The Magtrol Hysteresis Absorption Dynamometer will develop braking torque at any speed point, including low speed and stall conditions (“0” rpm). It is important to consider all torque points that are to be tested, not only rated torque, but also locked rotor and breakdown torque. Dynamometer selection should initially be based on the maximum torque requirement, subject to determining the maximum power requirements.

Maximum Speed

This rating is to be considered independent of torque and power requirements, and is the maximum speed at which the Dynamometer can be safely run under free-run or lightly loaded conditions. It is not to be considered as the maximum speed at which full braking torque can be applied.

Maximum Power Ratings

These ratings represent the maximum capability of the Dynamometer Braking System to absorb and dissipate heat generated when applying a braking load to the motor under test. The power absorbed and the heat generated by the Dynamometer is a function of the Torque (T) applied to the motor under test, and the resulting Speed (n) of the motor. This is expressed in these power (P) formulas:

$$\text{SI: } P \text{ (watts)} = T \text{ (N}\cdot\text{m)} \times n \text{ (rpm)} \times (1.047 \times 10^{-1})$$

$$\text{English: } P \text{ (watts)} = T \text{ (lb}\cdot\text{in)} \times n \text{ (rpm)} \times (1.183 \times 10^{-2})$$

$$\text{Metric: } P \text{ (watts)} = T \text{ (kg}\cdot\text{cm)} \times n \text{ (rpm)} \times (1.027 \times 10^{-2})$$

All of Magtrol’s controllers, readouts and software calculate horsepower as defined by 1 hp = 550 lb-ft / s. Using this definition:

$$\text{hp} = P \text{ (watts)} / 745.7$$

The Dynamometer’s ability to dissipate heat is a function of how long a load will be applied. For this reason, the maximum power ratings given are based on continuous operation under load, as well as a maximum of 5 minutes under load.

To safely dissipate heat and avoid Dynamometer failure, the maximum power rating is the most important consideration in selecting a Dynamometer.

Model	Torque Measure Unit Code	Maximum Torque Range	Drag Torque De-Energized at 1000 rpm	Nominal Input Inertia		Max. Power Ratings		Maximum Speed	Brake Cooling Method
						5 minute	continuous		
				<i>lb·ft·s²</i>	<i>kg·m²</i>	<i>W</i>	<i>W</i>	<i>rpm</i>	
HD-106	5N**	0.018 N·m	0.056 mN·m	7.04 × 10 ⁻⁷	9.54 × 10 ⁻⁷	35	7	30,000	Convection
	6N	2.50 oz·in	0.008 oz·in						
	7N	180.0 g·cm	0.57 g·cm						
	8N	18.00 mN·m	0.056 mN·m						
HD-100	5N**	0.08 N·m	0.64 mN·m	3.40 × 10 ⁻⁶	4.61 × 10 ⁻⁶	75	20	25,000	Convection
	6N	11.00 oz·in	0.09 oz·in						
	7N	800 g·cm	6.5 g·cm						
	8N	80.0 mN·m	0.64 mN·m						
HD-400	5N**	0.28 N·m	2 mN·m	1.55 × 10 ⁻⁵	2.10 × 10 ⁻⁵	200	55	25,000	Convection
	6N	40.0 oz·in	0.25 oz·in						
	7N	2.80 kg·cm	0.02 kg·cm						
	8N	280 mN·m	2 mN·m						
HD-500	5N**	0.85 N·m	5 mN·m	8.05 × 10 ⁻⁵	1.09 × 10 ⁻⁴	400	80	25,000	Convection
	6N	120.0 oz·in	0.5 oz·in						
	7N	8.50 kg·cm	0.05 kg·cm						
	8N	850 mN·m	5 mN·m						
HD-510	5N**	0.85 N·m	5 mN·m	8.05 × 10 ⁻⁵	1.09 × 10 ⁻⁴	750	375	25,000	Compressed Air* (7 CFM @ 1.75 PSI)
	6N	120.0 oz·in	0.5 oz·in						
	7N	8.50 kg·cm	0.05 kg·cm						
	8N	850 mN·m	5 mN·m						
HD-505	5N**	1.7 N·m	10 mN·m	1.61 × 10 ⁻⁴	2.18 × 10 ⁻⁴	800	160	25,000	Convection
	6N	240 oz·in	1.0 oz·in						
	7N	17.00 kg·cm	0.1 kg·cm						
	8N	1700 mN·m	10 mN·m						
HD-515	5N**	1.7 N·m	10 mN·m	1.61 × 10 ⁻⁴	2.18 × 10 ⁻⁴	1,500	900	25,000	Compressed Air* (10 CFM @ 4 PSI)
	6N	240 oz·in	1.0 oz·in						
	7N	17.00 kg·cm	0.1 kg·cm						
	8N	1700 mN·m	10 mN·m						
HD-700	5N**	3.10 N·m	0.013 N·m	5.51 × 10 ⁻⁴	7.47 × 10 ⁻⁴	700	150	25,000	Convection
	6N	440 oz·in	2.0 oz·in						
	7N	31.0 kg·cm	0.14 kg·cm						
	8N	3.10 N·m	0.013 N·m						
HD-710	5N**	3.10 N·m	0.013 N·m	5.51 × 10 ⁻⁴	7.47 × 10 ⁻⁴	1,500	935	25,000	Blower (included)
	6N	440 oz·in	2.0 oz·in						
	7N	31.0 kg·cm	0.14 kg·cm						
	8N	3.10 N·m	0.013 N·m						
HD-705	5N**	6.20 N·m	0.023 N·m	1.10 × 10 ⁻³	1.49 × 10 ⁻³	1,400	300	25,000	Convection
	6N	55.0 lb·in	0.2 lb·in						
	7N	62.0 kg·cm	0.24 kg·cm						
	8N	6.20 N·m	0.023 N·m						
HD-715	5N**	6.20 N·m	0.023 N·m	1.10 × 10 ⁻³	1.49 × 10 ⁻³	3,400	3,000	25,000	Blower (included)
	6N	55.0 lb·in	0.2 lb·in						
	7N	62.0 kg·cm	0.24 kg·cm						
	8N	6.20 N·m	0.023 N·m						
HD-800	5N**	14.00 N·m	0.10 N·m	4.43 × 10 ⁻³	6.01 × 10 ⁻³	2,800	1,800	12,000	Compressed Air* (7.5 CFM @ 7 PSI)
	6N	125.0 lb·in	0.8 lb·in						
	7N	140.0 kg·cm	1.0 kg·cm						
	8N	14.00 N·m	0.10 N·m						

* Requires air cooling provided by user. Regulator and filter package is provided as standard equipment on these units.

** 5 Volt output

HD-810	5N**	14.00 N·m	0.10 N·m	4.43×10^{-3}	6.01×10^{-3}	3,500	3,000	12,000	Blower (included)
	6N	125.0 lb·in	0.8 lb·in						
	7N	140.0 kg·cm	1.0 kg·cm						
	8N	14.00 N·m	0.10 N·m						
HD-805	5N**	28.0 N·m	0.14 N·m	8.81×10^{-3}	1.19×10^{-2}	5,300	3,000	12,000	Compressed Air* (15 CFM @ 7 PSI)
	6N	250 lb·in	1.2 lb·in						
	7N	280 kg·cm	1.5 kg·cm						
	8N	28.0 N·m	0.14 N·m						
HD-815	5N**	28.0 N·m	0.14 N·m	8.81×10^{-3}	1.19×10^{-2}	7,000	6,000	12,000	Blower (included)
	6N	250 lb·in	1.2 lb·in						
	7N	280 kg·cm	1.5 kg·cm						
	8N	28.0 N·m	0.14 N·m						
HD-825	5N**	56.5 N·m	0.22 N·m	1.85×10^{-2}	2.51×10^{-2}	14,000	12,000	8,000	Blower (included)
	6N	500 lb·in	3.5 lb·in						
	7N	565 kg·cm	4.0 kg·cm						
	8N	56.5 N·m	0.22 N·m						

* Requires air cooling provided by user. Regulator and filter package is provided as standard equipment on these units.

** 5 Volt output

Model	Torque Measure Unit Code	Maximum Torque Range	Drag Torque De-Energized at 1000 rpm	Nominal Input Inertia		Max. Power Ratings				Maximum Speed *	Brake Cooling Method
				lb·ft·s ²	kg·m ²	5 minute		continuous			
						hp	W	hp	W	rpm	
ED-715	5N**	6.20 N·m	0.035 N·m	1.27×10^{-3}	1.72×10^{-3}	5	3400	4	3000	25,000	Blower (included)
	6N	55.0 lb·in	0.3 lb·in								
	7N	62.0 kg·cm	0.36 kg·cm								
	8N	6.20 N·m	0.035 N·m								
ED-815	5N**	28.0 N·m	0.14 N·m	9.61×10^{-3}	1.30×10^{-2}	10	7000	8	6000	12,000	Blower (included)
	6N	250 lb·in	1.2 lb·in								
	7N	280 kg·cm	1.4 kg·cm								
	8N	28.0 N·m	0.14 N·m								

* The maximum speed will depend on what type of keyway (if any) is used on the shaft. Unless specified, the dynamometer shaft will be made without a keyway.

** 5 Volt Output

ELECTRICAL POWER AND FUSES

Model	Voltage	VA	Style	Rating		
HD-1XX-XN	120 V	30	UL/CSA	300 mA	250 V	SB
HD-1XX-XNA	240 V	30	IEC	125 mA	250 V	T
HD-4XX-XN	120 V	30	UL/CSA	300 mA	250 V	SB
HD-4XX-XNA	240 V	30	IEC	125 mA	250 V	T
HD-5XX-XN	120 V	30	UL/CSA	300 mA	250 V	SB
HD-5XX-XNA	240 V	30	IEC	125 mA	250 V	T
HD-800-XN	120 V	65	UL/CSA	800 mA	250 V	SB
HD-800-XNA	240 V	65	IEC	315 mA	250 V	T
HD-810-XN	120 V	65	UL/CSA	800 mA	250 V	SB
HD-810-XNA	240 V	65	IEC	315 mA	250 V	T
HD-805-XN	120 V	130	UL/CSA	1.25 A	250 V	SB
HD-805-XNA	240 V	130	IEC	630 mA	250 V	T
HD/ED-815-XN	120 V	130	UL/CSA	1.25 A	250 V	SB
HD/ED-815-XNA	240 V	130	IEC	630 mA	250 V	T
HD-825-XN	120 V	N/A	N/A	N/A		
HD-825-XNA	240 V	N/A	N/A	N/A		

BLOWER POWER AND FUSES

- Models HD-710, HD-715, HD-810 and ED-715 include the BL-001 blower.
- Models HD-815 and ED-815 include the BL-002 blower.
- Model HD-825 uses two BL-002 blowers for cooling its two brake sets.

Model	Voltage	VA	Style	Rating		
BL-001	120 V	600	UL/CSA	6.3 A	250 V	SB
BL-001A	240 V	500	IEC	3.15 A	250 V	T
BL-002	120 V	1000	UL/CSA	15 A	250 V	SB
BL-002A	240 V	1000	IEC	6.3 A	250 V	T

BLOWER DIMENSIONS

Allow approximately 6 in to 8 in (152 mm to 203 mm) between rear of dynamometer base plate and blower for connection hardware. Required hardware is supplied with the dynamometer.

BL-002 Blower has two filter elements.

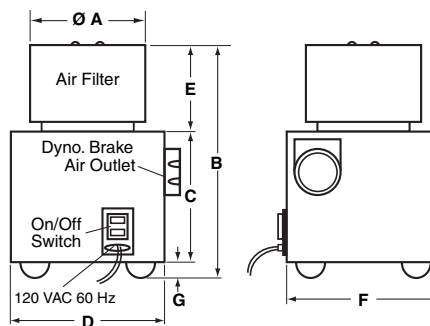

Model	BL-001		BL-002	
	in	mm	in	mm
Ø A	6	152	6	152
B	11	279	11	279
C	6	152	6	152
D	8	203	15	381
E	4	102	4	102
F	8	203	12	305
G	1	25	1	25
Weight	8.5 lb	3.9 kg	18 lb	8.1 kg

NOTE: Original dimensions are in English units. Dimensions converted to Metric units have been rounded and are for reference only.

HD-100/400/500 SERIES WITH LONG BASE PLATE

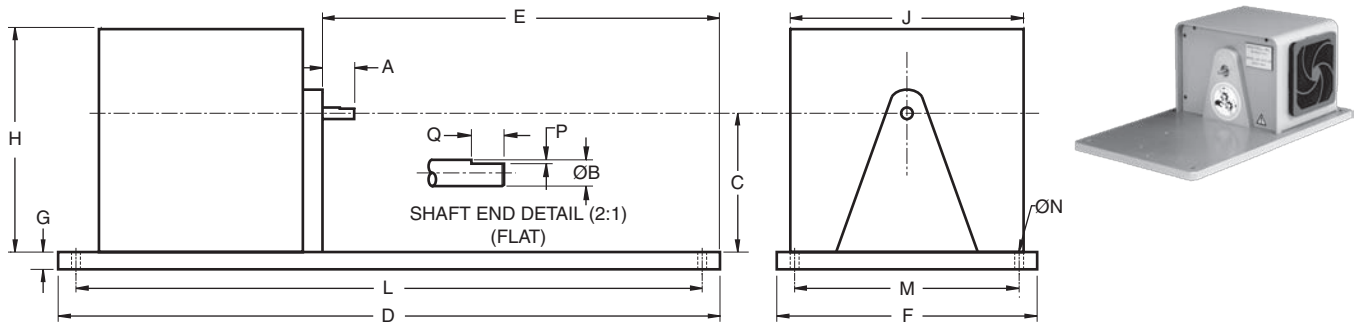

Model	units	A	Ø B	C	D	E	F	G	H	J	L*	M*	Ø N	P	Q	Weight
HD-106	in	0.50	0.1245/0.1247	3.5	17	9.38	10	0.5	6.3	8.5	15.5	8.5	0.37	0.015	0.375	12.0 lb
	mm	12.7	3.162/3.167	88.9	432	238.3	254	13	159	216	394	216	9.4	0.38	9.53	5.4 kg
HD-100	in	0.75	0.1870/0.1875	3.5	17	9.13	10	0.5	6.3	8.5	15.5	8.5	0.37	0.025	0.375	12.5 lb
	mm	19.1	4.750/4.763	88.9	432	231.9	254	13	159	216	394	216	9.4	0.64	9.53	5.7 kg
HD-400	in	0.67	0.2495/0.2497	3.5	17	9.13	10	0.5	6.3	8.5	15.5	8.5	0.37	0.03	0.438	15.0 lb
	mm	17.0	6.337/6.342	88.9	432	231.9	254	13	159	216	394	216	9.4	0.76	11.13	6.8 kg
HD-500	in	0.88	0.3745/0.3750	4.0	17	9.13	10	0.5	6.3	8.5	15.5	8.5	0.37	0.047	0.375	16.0 lb
	mm	22.2	9.512/9.525	101.6	432	231.9	254	13	159	216	394	216	9.4	1.19	9.53	7.3 kg
HD-510	in	0.88	0.3745/0.3750	4.0	17	9.13	10	0.5	6.3	8.5	15.5	8.5	0.37	N/A		16.0 lb
	mm	22.2	9.512/9.525	101.6	432	231.9	254	13	159	216	394	216	9.4			7.3 kg
HD-505	in	0.88	0.3745/0.3750	4.0	20	9.64	10	0.5	6.3	8.5	18.5	8.5	0.37	0.05	0.375	18.0 lb
	mm	22.2	9.512/9.525	101.6	508	244.9	254	13	159	216	470	216	9.4	1.27	9.53	8.1 kg
HD-515	in	0.88	0.3745/0.3750	4.0	20	9.64	10	0.5	6.3	8.5	18.5	8.5	0.37	N/A		18.0 lb
	mm	22.2	9.512/9.525	101.6	508	244.9	254	13	159	216	470	216	9.4			8.1 kg

HD-100/400/500 SERIES WITH SHORT BASE PLATE

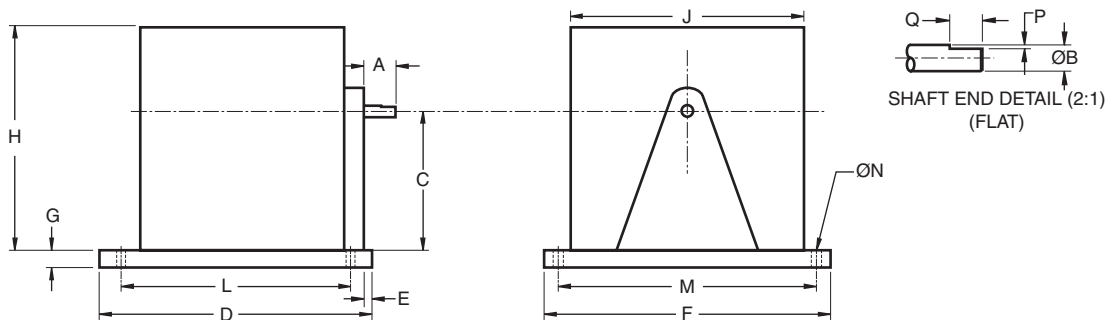

Model	units	A	Ø B	C	D	E	F	G	H	J	L*	M*	Ø N	P	Q	Weight
HD-106	in	0.50	0.1245/0.1247	3.5	7.0	0.33	11	0.5	6.3	8.5	6.0	9.84	0.35	0.015	0.375	7.5 lb
	mm	12.7	3.162/3.167	88.9	177.8	8.4	279.4	13	159	216	152.4	250	9	0.38	9.53	3.4 kg
HD-100	in	0.75	0.1870/0.1875	3.5	7.0	0.08	11	0.5	6.3	8.5	6.0	9.84	0.35	0.025	0.375	8.0 lb
	mm	19.1	4.750/4.763	88.9	177.8	2.1	279.4	13	159	216	152.4	250	9	0.64	9.53	3.6 kg
HD-400	in	0.67	0.2495/0.2497	3.5	7.0	0.08	11	0.5	6.3	8.5	6.0	9.84	0.35	0.03	0.438	11.0 lb
	mm	17.0	6.337/6.342	88.9	177.8	2.1	279.4	13	159	216	152.4	250	9	0.76	11.13	5.0 kg
HD-500	in	0.88	0.3745/0.3750	4.0	7.0	0.08	11	0.5	6.3	8.5	6.0	9.84	0.35	0.047	0.375	12.0 lb
	mm	22.2	9.512/9.525	101.6	177.8	2.1	279.4	13	159	216	152.4	250	9	1.19	9.53	5.4 kg
HD-510	in	0.88	0.3745/0.3750	4.0	8.0	0.13	11	0.5	6.3	8.5	7.0	9.84	0.35	N/A		12.5 lb
	mm	22.2	9.512/9.525	101.6	203.2	3.2	279.4	13	159	216	177.8	250	9			5.7 kg
HD-505	in	0.88	0.3745/0.3750	4.0	9.5	0.10	11	0.5	6.3	8.5	8.5	9.84	0.35	0.05	0.375	13.0 lb
	mm	22.2	9.512/9.525	101.6	241.3	2.6	279.4	13	159	216	215.9	250	9	1.27	9.53	5.9 kg
HD-515	in	0.88	0.3745/0.3750	4.0	10.25	0.10	11	0.5	6.3	8.5	9.25	9.84	0.35	N/A		13.0 lb
	mm	22.2	9.512/9.525	101.6	260.4	2.6	279.4	13	159	216	234.9	250	9			5.9 kg

* These dimensions represent the distance between mounting holes. There are four (4) mounting holes on each base plate.

HD-700 SERIES WITH LONG BASE PLATE

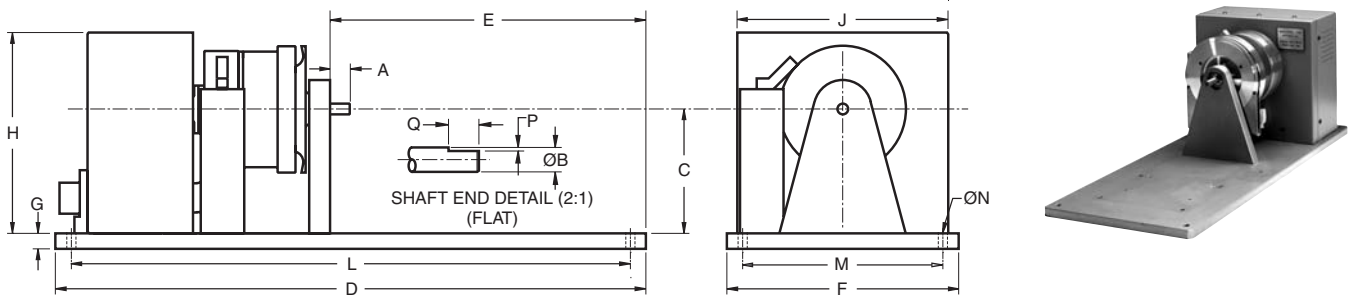

Model	units	A	Ø B	C	D	E	F	G	H	J	L*	M*	Ø N	P	Q	Weight
HD-700	in	1.25	0.4995/0.4999	5.875	24	12.75	11	0.625	9.5	10	22.5	9.5	0.375	0.06	0.63	39 lb
	mm	31.8	12.687/12.692	149.2	609.6	323.9	279.4	15.9	241.3	254	571.5	241.3	9.5	1.6	15.9	17.63 kg
HD-710	in	1.25	0.4995/0.4999	5.875	26	13.59	11	0.625	9.5	10	24.5	9.5	0.375	N/A		45 lb
	mm	31.8	12.687/12.697	149.2	660.4	345.2	279.4	15.9	241.3	254	622.3	241.3	9.5	N/A		20.30 kg
HD-705	in	1.25	0.4995/0.4999	5.875	28	13.62	11	0.625	9.5	10	26.5	9.5	0.375	0.06	0.63	52 lb
	mm	31.8	12.687/12.692	149.2	711.2	346.0	279.4	15.9	241.3	254	673.1	241.3	9.5	1.6	15.9	23.50 kg
HD-715	in	1.25	0.4995/0.4999	5.875	30	14.29	11	0.625	9.5	10	28.5	9.5	0.375	N/A		59 lb
	mm	31.8	12.687/12.697	149.2	762.0	363.0	279.4	15.9	241.3	254	723.9	241.3	9.5	N/A		26.60 kg

HD-700 SERIES WITH SHORT BASE PLATE

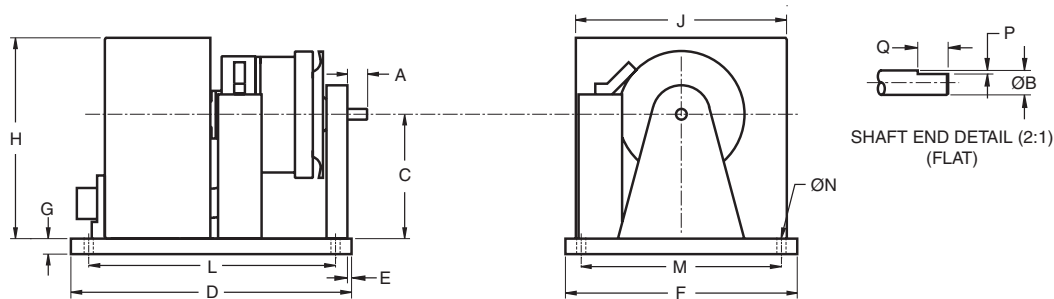

Model	units	A	Ø B	C	D	E	F	G	H	J	L*	M*	Ø N	P	Q	Weight
HD-700	in	1.25	0.4995/0.4999	5.875	11.34	0.09	11	0.625	9.5	10	9.84	9.84	0.35	0.06	0.63	30 lb
	mm	31.8	12.687/12.692	149.2	288.0	2.2	279.4	15.9	241.3	254	250.0	250	9	1.6	15.9	13.6 kg
HD-710	in	1.25	0.4995/0.4999	5.875	12.50	0.09	11	0.625	9.5	10	11.00	9.84	0.35	N/A		36 lb
	mm	31.8	12.687/12.697	149.2	317.5	2.3	279.4	15.9	241.3	254	279.5	250	9	N/A		16.3 kg
HD-705	in	1.25	0.4995/0.4999	5.875	14.45	0.07	11	0.625	9.5	10	12.95	9.84	0.35	0.06	0.63	43 lb
	mm	31.8	12.687/12.692	149.2	367.0	1.8	279.4	15.9	241.3	254	329.0	250	9	1.6	15.9	19.5 kg
HD-715	in	1.25	0.4995/0.4999	5.875	15.75	0.04	11	0.625	9.5	10	14.25	9.84	0.35	N/A		50 lb
	mm	31.8	12.687/12.697	149.2	400.0	1.1	279.4	15.9	241.3	254	362.0	250	9	N/A		22.7 kg

ED-SERIES ENGINE DYNAMOMETERS

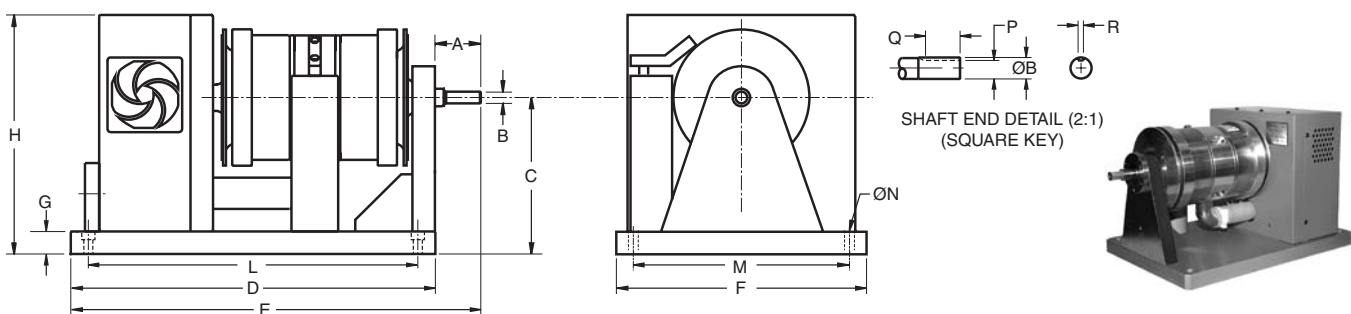

Model	units	A	Ø B	C	D	E	F	G	H	L*	M*	Ø N	P	Q	R	Weight
ED-715	in	1.72	0.7490/0.7495	6.87	16.00	18.13	11.00	1.00	10.50	14.50	9.50	0.37	0.64	1.00	0.187	75 lb
	mm	43.7	19.025/19.037	174.5	406.4	460.5	279.4	25.4	266.7	368.3	241.3	9.4	16.35	25.4	4.83	34 kg
ED-815	in	3.02	1.4995/1.5000	11.00	23.00	23.27	17.00	2.00	16.63	20.80	15.00	5/8-11	1.287	2.00	0.375	285 lb
	mm	76.7	38.087/38.100	279.4	584.2	591.1	431.8	50.8	422.4	528.3	381.0	THD	32.7	50.8	9.53	129.3 kg

* These dimensions represent the distance between mounting holes. There are four (4) mounting holes on each base plate.

HD-800 SERIES WITH LONG BASE PLATE

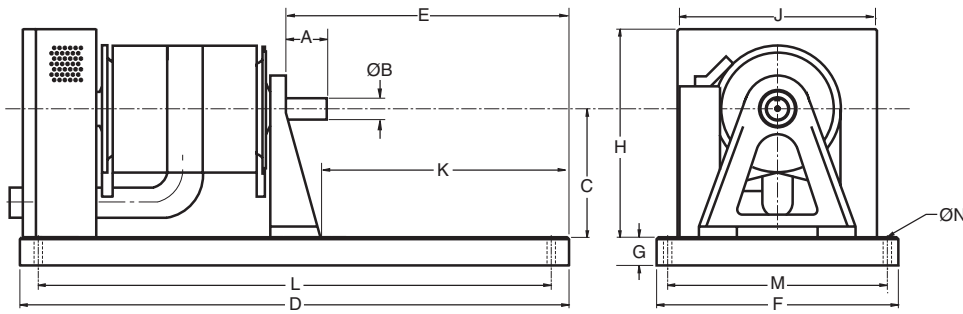

NOTE: For detailed dimension drawings of dynamometers with the T-slot base plate option, visit Magtrol's Web site.

Model	units	A	Ø B	C	D	E	F	G	H	J	K	L*	M*	Ø N	Weight
HD-800	in	2.13	0.9995/1.0000	9	38.5	23.81	17	2	14.6	14	21.4	36.5	15	0.54	237.0 lb
	mm	54	25.387/25.400	228.6	978	605	432	51	371	356	544	927	381	13.7	107.2 kg
HD-810	in	2.09	0.9995/1.0000	9	38.5	23.19	17	2	14.6	14	20.7	36.5	15	0.54	233.0 lb
	mm	53	25.387/25.400	228.6	978	589	432	51	371	356	526	927	381	13.7	105.3 kg
HD-805	in	2.13	0.9995/1.0000	9	38.5	20.57	17	2	14.6	14	18.2	36.5	15	0.54	287.0 lb
	mm	54	25.387/25.400	228.6	978	522	432	51	371	356	462	927	381	13.7	129.7 kg
HD-815	in	2.25	0.9995/1.0000	9	38.5	18.19	17	2	14.6	14	15.7	36.5	15	0.54	288.0 lb
	mm	57	25.387/25.400	228.6	978	462	432	51	371	356	399	927	381	13.7	130.1 kg

HD-800 SERIES WITH SHORT BASE PLATE

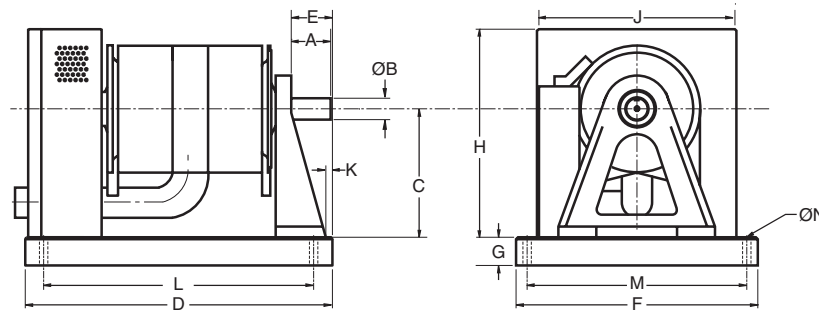

Model	units	A	Ø B	C	D	E	F	G	H	J	K	L*	M*	Ø N	Weight
HD-800	in	2.13	0.9995/1.0000	9	17.25	2.56	17	2	14.6	14	0.1	13.78	15.75	0.35	168.0 lb
	mm	54	25.387/25.400	228.6	438	65	432	51	371	356	2.5	350	400	9	76.2 kg
HD-810	in	2.09	0.9995/1.0000	9	18.00	2.59	17	2	14.6	14	0.1	14.06	15.75	0.35	164.0 lb
	mm	53	25.387/25.400	228.6	457	66	432	51	371	356	2.5	357	400	9	74.4 kg
HD-805	in	2.13	0.9995/1.0000	9	20.50	2.57	17	2	14.6	14	0.1	15.75	15.75	0.35	228.0 lb
	mm	54	25.387/25.400	228.6	520	65	432	51	371	356	2.5	400	400	9	103.4 kg
HD-815	in	2.12	0.9995/1.0000	9	23.00	2.59	17	2	14.6	14	0.2	19.09	15.75	0.35	236.0 lb
	mm	54	25.387/25.400	228.6	584	66	432	51	371	356	5.1	485	400	9	107.0 kg

An HD-825 Dynamometer with long base plate is available if ordered with the accompanying dynamometer table (TAB 0825L). Contact Magtrol for details.

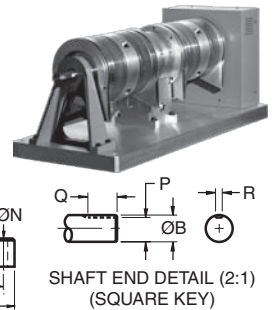
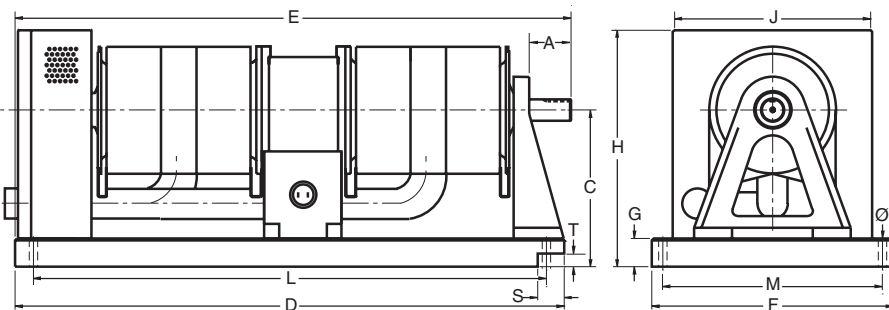

Model	units	A	Ø B	C	D	E	F	G	H	J	L*	M*	Ø N	P	Q	R	S	T	Weight
HD-825	in	2.83	1.4995/1.5000	11	38.5	38.93	17	2	16.6	14	36.5	15	0.54	1.287	2	0.376	2	1	400.0 lb
	mm	72	38.087/38.100	279.4	978	989	432	51	422	356	927	381	13.7	32.69	50.8	9.53	50.8	25.4	181.4 kg

* These dimensions represent the distance between mounting holes. There are four (4) mounting holes on each base plate.

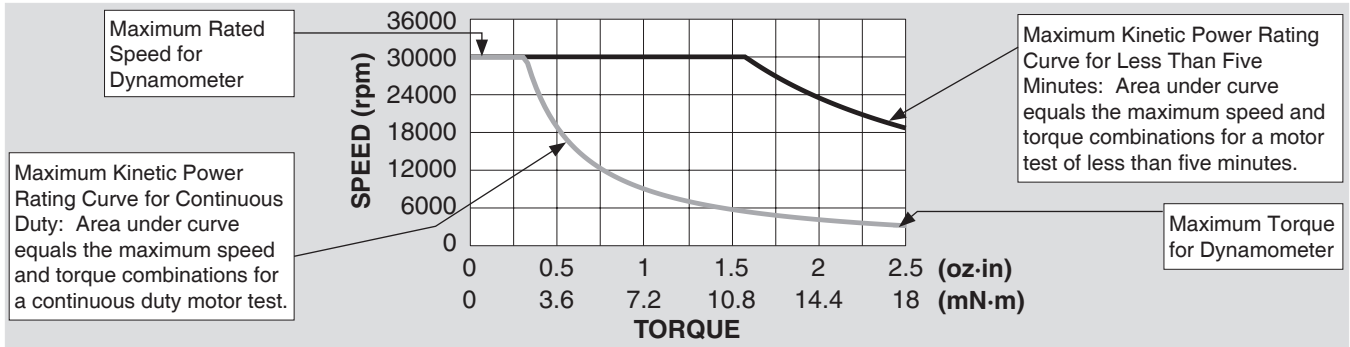

HD-106

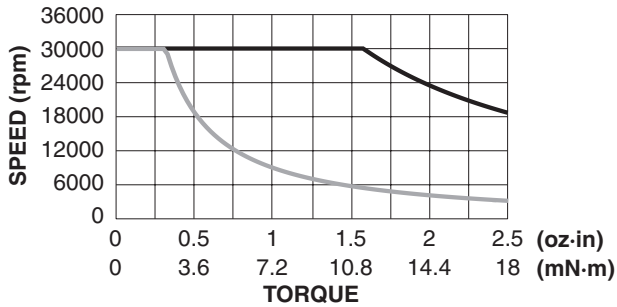

The power absorption curves represent the maximum power (heat) that the dynamometer can dissipate over time.

HD-100

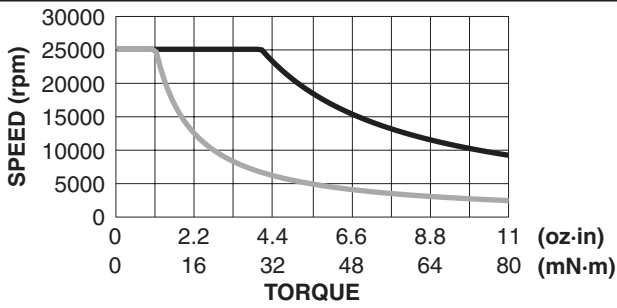

HD-400

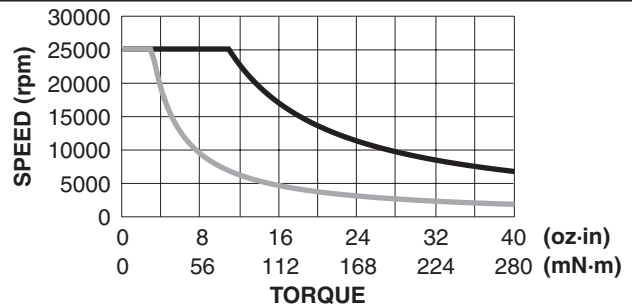

HD-500

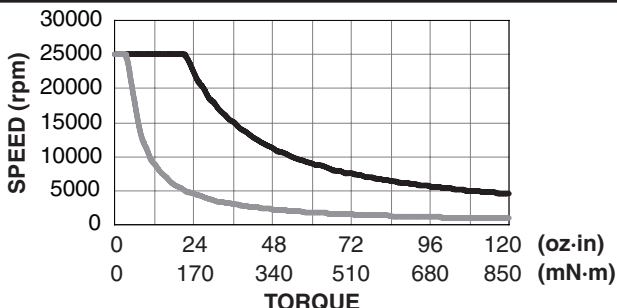

HD-510

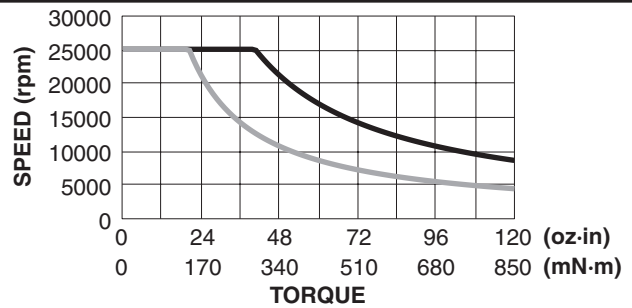

HD-505

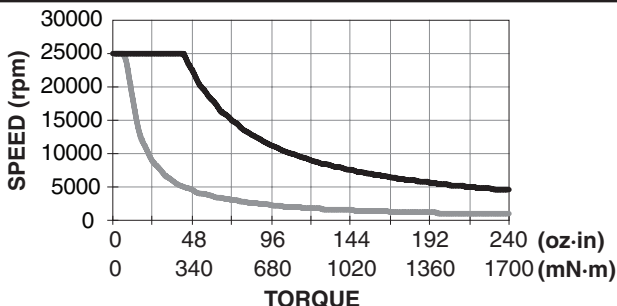

HD-515

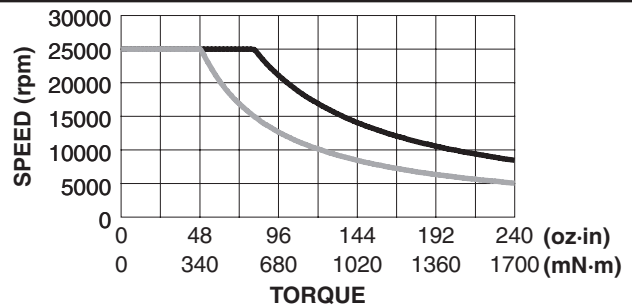

HD-700

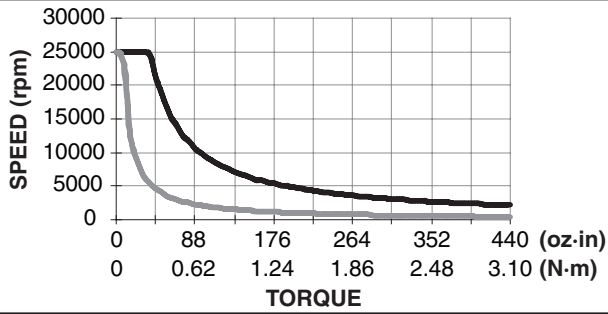

HD-710

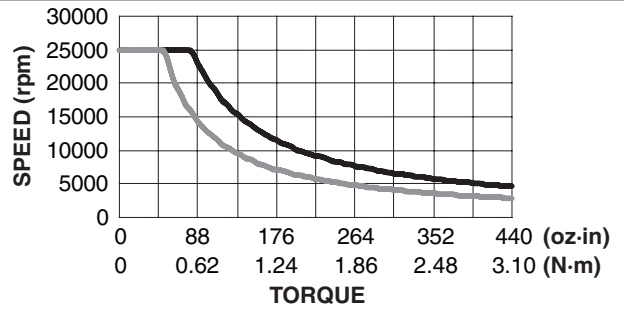

HD-705

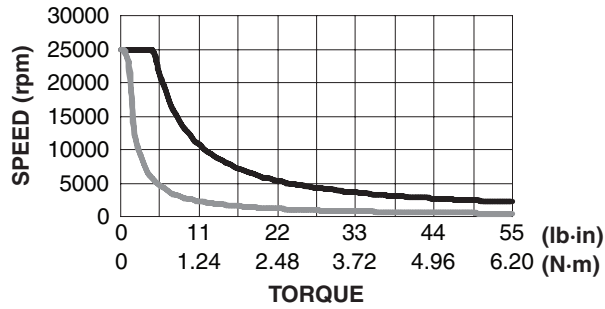

HD-715 and ED-715

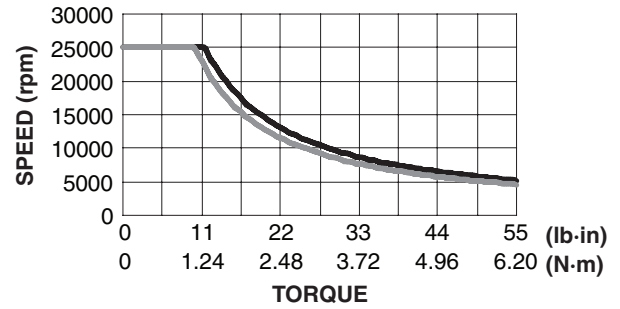

HD-800

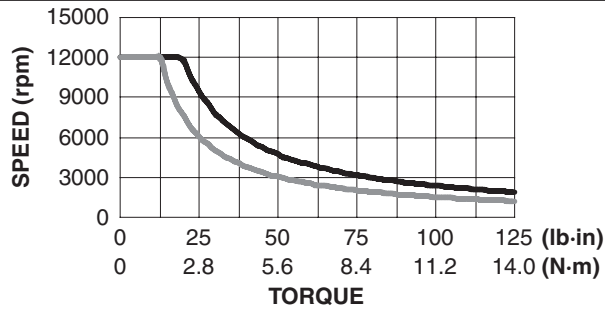

HD-810

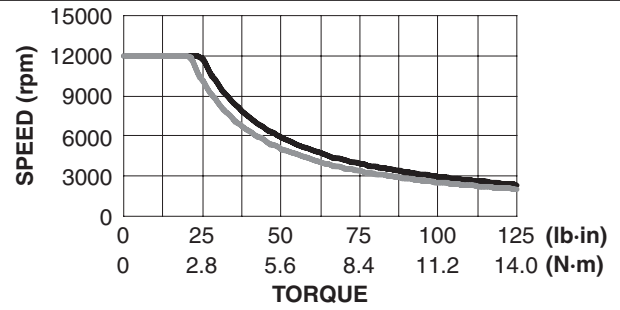

HD-805

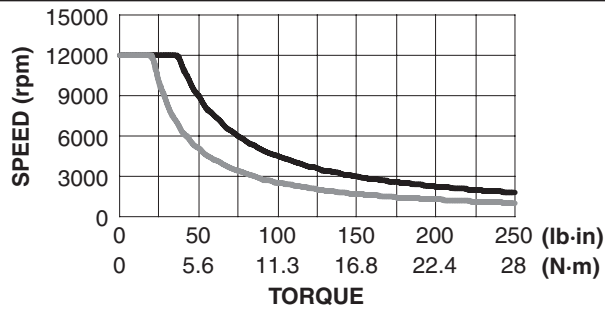

HD-815 and ED-815

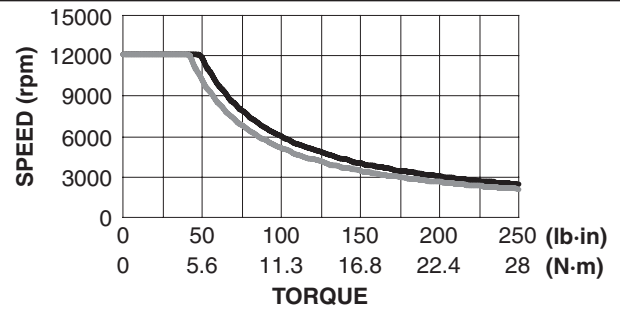

HD-825

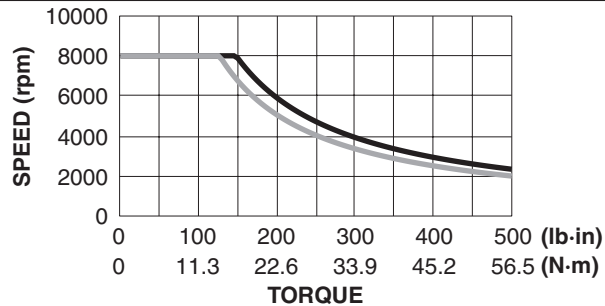

The power absorption curves represent the maximum power (heat) that the dynamometer can dissipate over time.

OPEN LOOP SYSTEMS

Magtrol offers both open loop manual test systems and PC-based closed loop test systems. A typical open loop system will consist of a Dynamometer and a Magtrol 6200 Open-Loop Controller. A Magtrol Single or Three-Phase Power Analyzer, which allows for the capturing of volts, amps, watts and power factor, can be included as an option. An open loop system is often used for quick pass/fail testing on the production line or at incoming inspection. Magtrol's 6200 Controller provides pass/fail testing as a standard feature.

Dynamometer with 6200 Controller

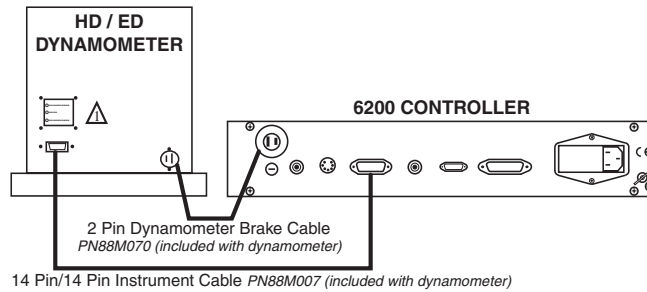

CLOSED LOOP SYSTEMS

In a closed loop motor test system, data is collected on a PC using Magtrol's M-TEST Software, DSP6001 Programmable Dynamometer Controller, and requisite interface cards and cables. Magtrol's Model 6200 and DSP6001 Controllers compute and display mechanical power (in horsepower or watts) in addition to torque and speed. A Single or Three Phase Power Analyzer, a required component in a test system measuring motor efficiency, can be integrated into this system as well as Magtrol's Temperature Testing Hardware.

Dynamometer with DSP6001 Controller and M-TEST Software

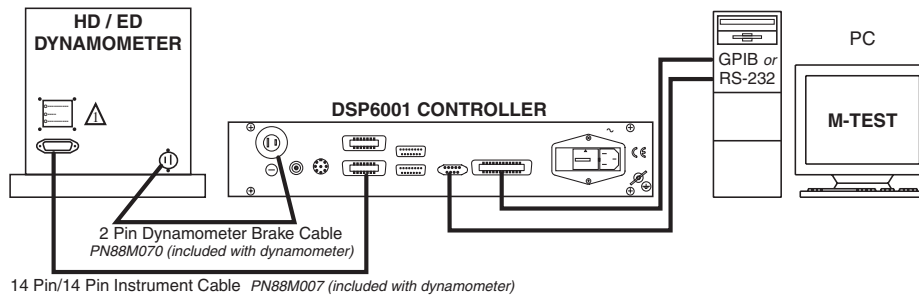

Dynamometer with 6510e Power Analyzer, DSP6001 Controller and M-TEST Software

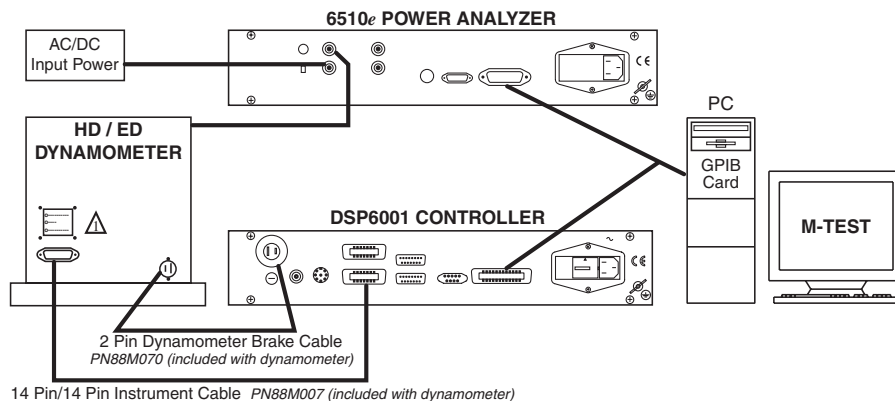

CUSTOM MOTOR TEST SYSTEM

HD Series Hysteresis Dynamometers can be incorporated into a Customized Motor Test System. These PC based, turn-key systems are custom designed and built to meet specific user requirements.

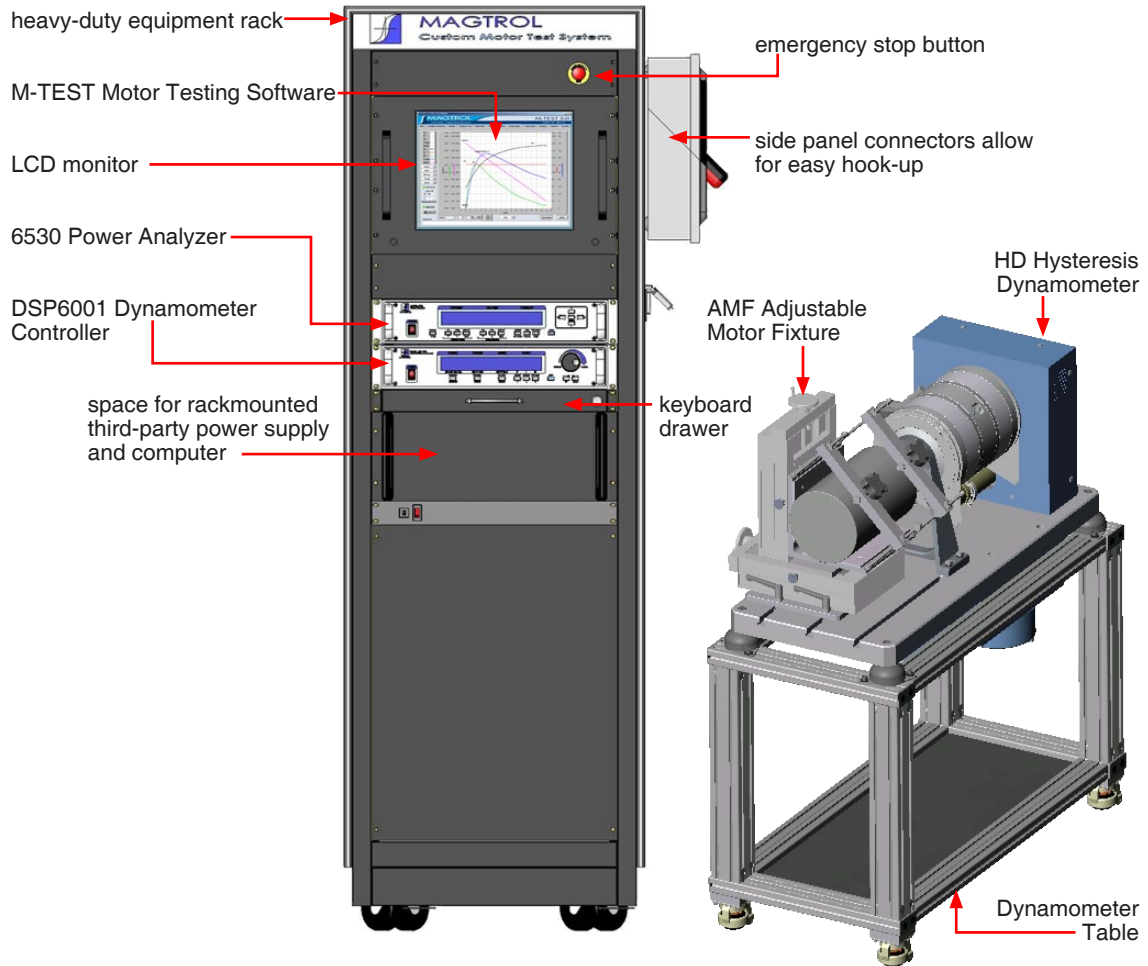

DYNAMOMETER OPTIONS

Encoder Options For Low Speed Testing

For low speed motors, such as gear motors with maximum speeds of less than 200 rpm, Magtrol offers additional encoder options that allow for increased resolution of the speed signal.

T-Slot Base Plate

To accommodate Magtrol AMF-3 Adjustable Motor Fixtures, a grooved base plate with three M12 T-slots, one centered and two 250 mm apart, is available on all HD-800 series dynamometers.

CUSTOM DYNAMOMETERS

High Speed Testing

For certain models, Magtrol can provide Dynamometers which can operate at higher than rated speeds.

Mechanical Modifications

Magtrol can provide customized base plates, riser blocks and shaft modifications.

ORDERING INFORMATION

MODEL NUMBER:	<input type="checkbox"/> D - <input type="checkbox"/> <input type="checkbox"/> <input type="checkbox"/> - <input type="checkbox"/> N <input type="checkbox"/> - 0 <input type="checkbox"/> <input type="checkbox"/> <input type="checkbox"/>
DYNAMOMETER TYPE	
• Hysteresis _____	HD 100-825
• Engine _____	ED 715-815
TORQUE UNITS	
• 5 V Output _____	5N
• English (U.S.) _____	6N
• Metric _____	7N
• SI _____	8N
POWER OPERATION	
• 120 VAC (standard) _____	(blank)
• 240 VAC (option) _____	A
BASE PLATE	
• long _____	0
• short _____	1
• long with T-slots (available on HD-800 series only) _____	2
• ED dynamometers _____	0
SPEED ENCODER	
• 60 bit (standard) _____	00
• 60 and 600 bit _____	30
• 60 and 6000 bit _____	40
*Contact sales regarding speed encoders for HD-100 through HD-500 series dynamometers.	

SYSTEM OPTIONS AND ACCESSORIES

CATEGORY	DESCRIPTION	MODEL / PART #
CONTROLLERS	High-Speed Programmable Dynamometer Controller	DSP6001
	Open Loop Dynamometer Controller	6200
POWER ANALYZERS	High-Speed Single-Phase Power Analyzer	6510e
	High-Speed Three-Phase Power Analyzer	6530
SOFTWARE	M-TEST 5.0 Motor Testing Software	SW-M-TEST5.0-WE
	Temperature Testing Hardware	HW-TTEST
POWER SUPPLIES	Power Amplifier – <i>required for all HD-825 dynamometers</i>	5241
MISC. ELECTRONICS	Manually Controlled Switch Box	5500
	Direction Indicator	5600
DYNAMOMETER TABLES	Table (with grooved table top) for HD-100/400/500/700 series short base plate dynamometers and ED-715*	TAB 1457S
	Table (drilled and tapped) for HD-100/400/500/700 series long base plate dynamometers	TAB 1457L
	Table for HD-800 series long base plate dynamometers and ED-815* (base of dynamometer also serves as the table top)	TAB 0800L
	Table for HD-825 long base plate dynamometers	TAB 0825L
MOTOR FIXTURES	Adjustable Motor Fixtures	AMF Series
	Fixed Motor Fixtures	FMF Series
CALIBRATION	Calibration Beam Assemblies and Calibration Weights	CB and WT Series

* Mounting of ED Engine Dynamometers to dynamometer tables requires certain modifications. Contact Magtrol for details.

Due to the continual development of our products, we reserve the right to modify specifications without forewarning.



www.magtrol.com

MAGTROL INC

70 Gardenville Parkway
Buffalo, New York 14224 USA
Phone: +1 716 668 5555
Fax: +1 716 668 8705
E-mail: magtrol@magtrol.com

MAGTROL SA

Route de Montena 77
1728 Rossens/Fribourg, Switzerland
Phone: +41 (0)26 407 3000
Fax: +41 (0)26 407 3001
E-mail: magtrol@magtrol.ch

Subsidiaries in:

Germany • France
China • India

Worldwide Network
of Sales Agents

