

MD-01 Transducers

FEATURES

- Nominal capacity: 200 N, 500 N, 1 kN, 2 kN, 5 kN, 10kN and 20 kN
- Cost effective: high accuracy and long service reliability
- Damage-resistant: no mechanically sensitive parts
- Resistant to chemical media: can be used in humid environments and in chemical plants
- Welded stainless steel housing; IP 67 protection class
- Small size: ideal for space-saving applications
- Simple installation: single-screw mounting (M6)



DESCRIPTION

Magtrol's MD-01 Transducers are designed for measuring static and dynamic compression loads. Using strain gauge technology, deformation of the sensing element provides an electrical signal proportional to the load or force being measured.

With quick single-screw mounting, this transducer can be easily integrated into wide array of applications.

APPLICATIONS

Made entirely of stainless steel, this hermetically-sealed transducer can be use anywhere without restriction.

When connected to a signal conditioner, this high-accuracy transducer ideally suited to applications where weights have to be measured like hoppers/silos, platforms etc.

SYSTEM CONFIGURATION

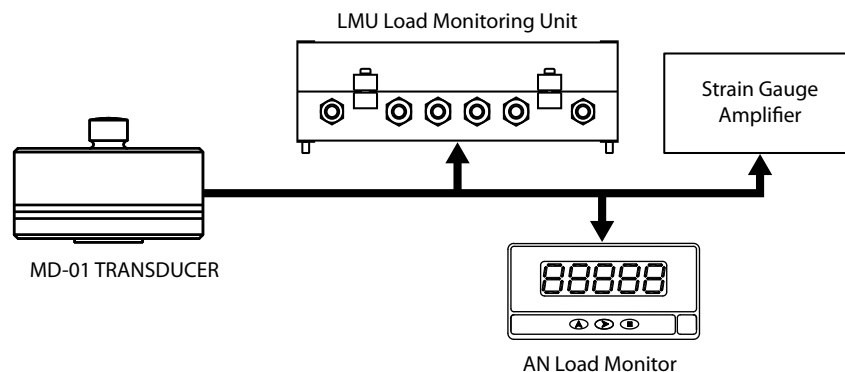

ORDERING INFORMATION

PART NUMBER MD-01- - B
 Nominal Force:
 (N) 200 or 500 _____
 (kN) 1, 2, 5, 10 and 20 _____

TECHNICAL RATINGS

	MD-01-B
MECHANICAL CHARACTERISTICS	
Nominal Force	200 N, 500 N, 1 kN, 2 kN, 5 kN, 10 kN or 20 kN
Accuracy Class	0.2
Admissible Overload	120%
Overload Limit	150%
Overload at Rupture	> 300%
Maximum Dynamic Load (double amplitude)	70%
Flexion at Nominal Force	≈ 0.1 mm to 0.3 mm (depending on model)
Weight	≈ 0.3 kg
ELECTRICAL CHARACTERISTICS	
Nominal Sensitivity	2 mV/V ± 0.5 %
Bridge Impedence: Input	350 Ω
Bridge Impedence: Output	700 Ω
Insulation Resistance	> 5 × 10 ⁹ Ω
Nominal Supply Voltage	0.5 V to 10 V
Combined Error (nonlinearity + hysteresis)	≤ ± 0.2%
ENVIRONMENTAL CHARACTERISTICS	
Reference Temperature	+23 °C
Operating Temperature (compensated)	-10 °C to +60 °C
Usable Temperature Range	-40 °C to +80 °C
Temperature Influence: On Zero	< ± 0.01% / K
Temperature Influence: On Sensitivity	< ± 0.01% / K
Protection Class	IP 67
CONNECTION CABLE	
Cable Length	1.5 m

DIMENSIONS

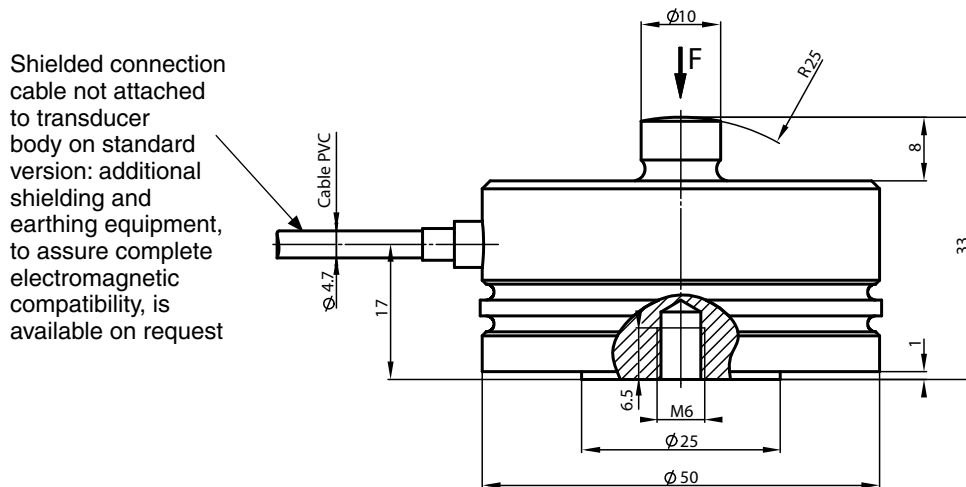

Shielded connection cable not attached to transducer body on standard version: additional shielding and earthing equipment, to assure complete electromagnetic compatibility, is available on request

PIN CONNECTIONS

Pin	Color Code
+ supply	brown
- supply	yellow
+ signal	green
- signal	white

Due to the continual development of our products, we reserve the right to modify specifications without forewarning.



www.magtrol.com

MAGTROL INC
 70 Gardenville Parkway
 Buffalo, New York 14224 USA
 Phone: +1 716 668 5555
 Fax: +1 716 668 8705
 E-mail: magtrol@magtrol.com

MAGTROL SA
 Route de Montena 77
 1728 Rossens/Fribourg, Switzerland
 Phone: +41 (0)26 407 3000
 Fax: +41 (0)26 407 3001
 E-mail: magtrol@magtrol.ch

Subsidiaries in:
 Germany • France
 China • India
 Worldwide Network
 of Sales Agents

