ZL-03

Traction Force Transducer

FEATURES

- Nominal load 10 kN, 25 kN, 50 kN, 75 kN or 100kN
- Pendulum bearings maintenance-free
- Large safety also for long-term dynamic requests
- Large overload capacity
- High precision
- Excellent long-term stability
- IP 65 protection class



DESCRIPTION

The Magtrol ZL-03 Traction Force Transducer work with the Strain Gauge Technologie and was elaborate to support the load for long-term dynamic requests. Connected to a conditioning electronic, the transducer will give signal proportional to the measured load.

APPLICATIONS

The compact design along with the high protection class issue to this transducer an excellent applicability to measure and monitoring the forces on crane cables, overload protection for elevators, along with all other load measurements in different environments.

SYSTEM CONFIGURATION

PIN CONNECTION

Signal	Transducer pin	Color code
+ supply	(A)	brown
- supply	(B)	yellow
+ signal	(C)	white
- signal	(D)	green

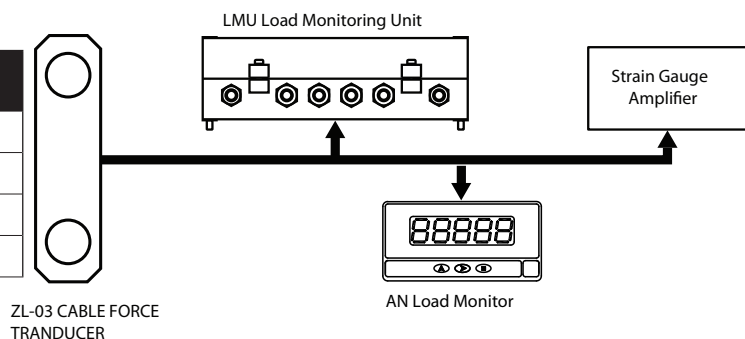

ORDERING INFORMATION

CABLE FORCE TRANSDUCER

Part Number (P/N)

- Nominal load (kN) : 10, 25, 50, 75 ou 100

ZL-03 - - B

ACCESSORIES

Connection cable assembly (P/N)

ZL-03-10-10

TECHNICAL RATINGS

ZL-03-B	
MECHANICAL CHARACTERISTICS	
Nominal Load	10, 25, 50, 75 or 100 kN
Overload Admissible	150 %
Breaking Overload	≥ 500 %
ELECTRICAL CHARACTERISTICS	
Nominal Sensitivity	1mV/V
Input Bridge Impedance	380 Ω (+40 Ω / -30 Ω)
Output Bridge Impedance	350 Ω ± 2 Ω
Isolation Resistance	> 5 GΩ
Surface protection	galvanised
Power Supply	5-15 V
Combined Error (non linearity + hysteresis)	< ± 0.5 %
ENVIRONMENTAL CHARACTERISTICS	
Nominal Temperature	- 10 °C to + 40 °C
Operating Temperature	- 10 °C to + 60 °C
Temperature coefficient of signal zero per 10 K . for nominal temperature range . for operating temperature range	< ± 0.1 % < ± 0.2 %
Temperature coefficient of sensibility per 10 K . for nominal temperature range . for operating temperature range	< ± 0.1 % < ± 0.1 %
ELECTRICAL CONNECTION	
Connector	MS 3012 A 4 poles
Cable assembly	ZL-03-10-10 (option)
Cable length	3 m

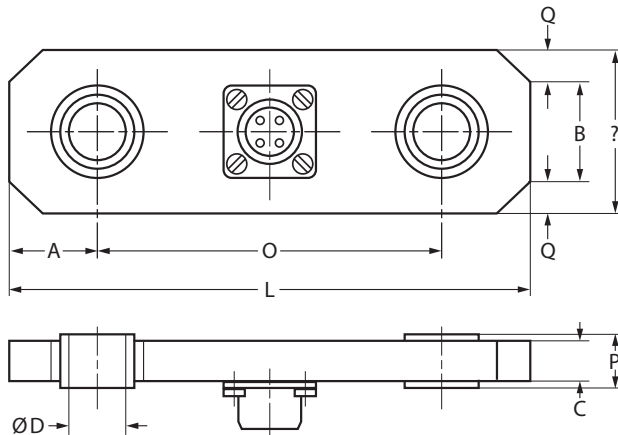
DIMENSIONS

Dimensions (mm)	Nominal load				
	10 kN	25 kN	50 kN	75 kN	100 kN
A	27	44	58	72	90
B	50	80	100	125	150
C	10	16	20	25	30
ØD	17	25	35	45	50
L	162	248	326	390	500
P	14	20	25	32	35
Qx45°	8	20	16	18	25
O	108	160	210	246	320

Due to the continual development of our products, we reserve the right to modify specifications without forewarning.

www.magtrol.com
MAGTROL INC

70 Gardenville Parkway
Buffalo, New York 14224 USA
Phone: +1 716 668 5555
Fax: +1 716 668 8705
E-mail: magtrol@magtrol.com

MAGTROL SA

Route de Montena 77
1728 Rossens/Fribourg, Switzerland
Phone: +41 (0)26 407 3000
Fax: +41 (0)26 407 3001
E-mail: magtrol@magtrol.ch

Subsidiaries in:

Germany • France
China • India
Worldwide Network
of Sales Agents

