

**MAGTROL**

# **Model 3410 Torque Display**



**User's Manual**

## Purchase Record

Please record all model numbers and serial numbers of your Magtrol equipment, along with the general purchase information. The model number and serial number can be found on either a silver identification plate or white label affixed to each unit. Refer to these numbers whenever you communicate with a Magtrol representative about this equipment.

Model Number: \_\_\_\_\_

Serial Number: \_\_\_\_\_

Purchase Date: \_\_\_\_\_

Purchased From: \_\_\_\_\_

---

While every precaution has been exercised in the compilation of this document to ensure the accuracy of its contents, Magtrol, Inc. assumes no responsibility for errors or omissions. Additionally, no liability is assumed for any damages that may result from the use of the information contained within this publication.

### **COPYRIGHT**

Copyright ©2005–2010 Magtrol, Inc. All rights reserved.

Copying or reproduction of all or any part of the contents of this manual without the express permission of Magtrol is strictly prohibited.

### **TRADEMARKS**

LabVIEW™ is a trademark of National Instruments Corporation.

National Instruments™ is a trademark of National Instruments Corporation.

Windows® is a registered trademark of Microsoft Corporation.

---

# Safety Precautions

---



1. Make sure that all Magtrol Torque Transducers and electronic products are earth-grounded, to ensure personal safety and proper operation.
2. Make sure that torque transducers and motors under test are equipped with appropriate safety guards.

---

# Revisions To This Manual

---

The contents of this manual are subject to change without prior notice. Should revisions be necessary, updates to all Magtrol User's Manuals can be found at Magtrol's web site at [www.magtrol.com/support/manuals.htm](http://www.magtrol.com/support/manuals.htm).

Please compare the date of this manual with the revision date on the web site, then refer to the manual's Table of Revisions for any changes/updates that have been made since this edition.

## REVISION DATE

Preliminary Manual, revision F – September 2010

## TABLE OF REVISIONS

Date	Edition	Change	Section(s)
09/21/10	Preliminary manual, rev. F	TF models 205 and 209 added	5.2.2.1
05/14/10	Preliminary manual, rev. E	TF models 205 and 209 added	4.1.2
02/10/09	Preliminary manual, rev. D	Pin 2 of RS-232C connector changed from "RX" to "TX". Pin 3 of RS-232C connector changed from "TX" to "RX".	2.2.1, 5.1
12/18/08	Preliminary manual, rev. C	Deca-Newton meters (daN-m) added to torque units selection	4.1.3, 5.2.2
12/18/08	Preliminary manual, rev. C	TF 220 added to model selection	4.1.2, 5.2.2.1
08/24/07	Preliminary manual, rev. B	*IDN? command added	5.2.1
08/24/07	Preliminary manual, rev. B	OD command data string changed	5.2.1
08/24/07	Preliminary manual, rev. B	TM 301 and 302 added to model selection/codes	4.1.2, 5.2.2.1
07/20/06	Preliminary manual, rev. A	Speed Output BNC changed to 3.3 VHC pulse (buffered from transducer)	1.3
07/20/06	Preliminary manual, rev. A	To accommodate Magtrol Dial Weight Dynamometers: Pin 7 of TRANSDUCER connector changed from "N/C" to "5 V OUT". Pin 8 of TRANSDUCER connector changed from "N/C" to "5 V COM".	2.2.1

---

# Table of Contents

---

<b>SAFETY PRECAUTIONS .....</b>	<b>I</b>
<b>REVISIONS TO THIS MANUAL .....</b>	<b>II</b>
REVISION DATE.....	II
TABLE OF REVISIONS.....	II
<b>TABLE OF CONTENTS .....</b>	<b>III</b>
<b>PREFACE.....</b>	<b>VI</b>
PURPOSE OF THIS MANUAL .....	VI
WHO SHOULD USE THIS MANUAL.....	VI
MANUAL ORGANIZATION .....	VI
CONVENTIONS USED IN THIS MANUAL.....	VII
<b>1. INTRODUCTION .....</b>	<b>1</b>
1.1 UNPACKING YOUR 3410 TORQUE DISPLAY.....	1
1.2 FEATURES OF THE 3410 TORQUE DISPLAY .....	1
1.3 DATA SHEET.....	2
<b>2. CONTROLS.....</b>	<b>4</b>
2.1 FRONT PANEL.....	4
2.2 REAR PANEL.....	5
2.2.1 REAR PANEL INPUTS AND OUTPUTS .....	5
2.2.2 REAR PANEL CONTROLS AND BUTTONS.....	6
<b>3. INSTALLATION/CONFIGURATION.....</b>	<b>7</b>
3.1 POWERING UP THE 3410 .....	7
3.1.1 LINE VOLTAGE.....	7
3.1.2 SELF-TEST.....	7
3.1.3 MAIN MENU .....	8
<b>4. MANUALLY CONTROLLED OPERATION .....</b>	<b>9</b>
4.1 SETTING DESIRED OPERATING PARAMETERS .....	9
4.1.1 DEVICE SETUP.....	9
4.1.2 MODEL SELECTION.....	10
4.1.3 TORQUE UNITS SETUP.....	11
4.1.4 POWER UNITS SETUP.....	11
4.1.5 CONTRAST SETUP .....	12
4.1.6 SYSTEM SETUP CHECK .....	12
4.1.7 TARE FUNCTION .....	13
4.1.8 BITE FUNCTION.....	13
<b>5. COMPUTER CONTROLLED OPERATION .....</b>	<b>14</b>
5.1 ABOUT THE RS-232 INTERFACE.....	14
5.1.1 CONNECTION.....	14
5.1.2 COMMUNICATION PARAMETERS .....	14
5.2 3410 COMMAND SET.....	15
5.2.1 COMMUNICATION COMMANDS.....	15

---

5.2.2	SETUP COMMANDS .....	15
5.3	CALIBRATION COMMANDS.....	17
<b>6.</b>	<b>CALIBRATION .....</b>	<b>18</b>
6.1	CLOSED-BOX CALIBRATION .....	18
6.2	CALIBRATION SCHEDULE.....	18
6.3	BASIC CALIBRATION PROCESS.....	18
6.3.1	INITIAL CALIBRATION PROCEDURE.....	18
6.3.2	TORQUE OFFSET AND GAIN.....	18
<b>7.</b>	<b>TROUBLESHOOTING.....</b>	<b>19</b>
	<b>APPENDIX A: SCHEMATICS .....</b>	<b>20</b>
A.1	78P205 BOARD .....	20
	<b>GLOSSARY.....</b>	<b>21</b>
	<b>INDEX.....</b>	<b>22</b>
	<b>SERVICE INFORMATION.....</b>	<b>23</b>
	RETURNING MAGTROL EQUIPMENT FOR REPAIR AND/OR CALIBRATION .....	23
	RETURNING EQUIPMENT TO MAGTROL, INC. (UNITED STATES).....	23
	RETURNING EQUIPMENT TO MAGTROL SA (SWITZERLAND).....	23

## TABLE OF FIGURES

### 2. CONTROLS

<i>Figure 2-1 Front Panel</i> .....	4
<i>Figure 2-2 Rear Panel</i> .....	5
<i>Figure 2-3 Transducer Connector</i> .....	5
<i>Figure 2-4 RS-232C Interface</i> .....	5

### 3. INSTALLATION/CONFIGURATION

<i>Figure 3-1 Cable and Connection Diagrams</i> .....	7
<i>Figure 3-2 Title Display</i> .....	8
<i>Figure 3-3 Revision Display</i> .....	8
<i>Figure 3-4 Main Menu</i> .....	8

### 4. MANUALLY CONTROLLED OPERATION

<i>Figure 4-1 System Display</i> .....	9
<i>Figure 4-2 Device Setup Menu</i> .....	9
<i>Figure 4-3 Saving System Display</i> .....	9
<i>Figure 4-4 Model Selection Menu</i> .....	10
<i>Figure 4-5 Torque Units Setup Menu</i> .....	11
<i>Figure 4-6 Power Units Setup Menu</i> .....	11
<i>Figure 4-7 Contrast Setup Menu</i> .....	12
<i>Figure 4-8 System Check Display Example</i> .....	12
<i>Figure 4-9 BITE Display</i> .....	13

### 5. COMPUTER CONTROLLED OPERATION

<i>Figure 5-1 RS-232 Interface</i> .....	14
<i>Figure 5-2 Cable Connection</i> .....	14

---

# Preface

---

## PURPOSE OF THIS MANUAL

This manual contains all the information required for the installation and general use of the Model 3410 Torque Display. To achieve maximum capability and ensure proper use of the instrument, please read this manual in its entirety before operating. Keep the manual in a safe place for quick reference whenever a question should arise.

## WHO SHOULD USE THIS MANUAL

This manual is intended for bench test operators who are going to use the 3410 Torque Display in conjunction with any Magtrol TM In-Line Torque Transducer and TF Torque Flange Sensor.

## MANUAL ORGANIZATION

This section gives an overview of the structure of the manual and the information contained within it. Some information has been deliberately repeated in different sections of the document to minimize cross-referencing and to facilitate understanding through reiteration.

The structure of the manual is as follows:

- Chapter 1: INTRODUCTION - Contains the technical data sheet for the 3410 Torque Transducer Display, which describes the unit and provides its mechanical and electrical characteristics.
- Chapter 2: CONTROLS - Description of the elements located on the front and rear panels of the unit.
- Chapter 3: INSTALLATION/CONFIGURATION - Provides information needed for setup of the 3410.
- Chapter 4: MANUALLY CONTROLLED OPERATION - How to run a test when the 3410 is used as a stand-alone unit.
- Chapter 5: COMPUTER CONTROLLED OPERATION - How to run a test when the 3410 is used with a personal computer. Includes information on serial (RS-232) interface and command set.
- Chapter 6: CALIBRATION - Provides recommended calibration schedules along with step-by-step instructions for the calibration procedure.
- Chapter 7: TROUBLESHOOTING - Solutions to common problems encountered during setup and testing.
- Appendix A: SCHEMATICS - For the analog section.
- Glossary: List of abbreviations and terms used in this manual, along with their definitions.

---

## CONVENTIONS USED IN THIS MANUAL

The following symbols and type styles may be used in this manual to highlight certain parts of the text:



---

**Note:** This is intended to draw the operator's attention to complementary information or advice relating to the subject being treated. It introduces information enabling the correct and optimal functioning of the product to be obtained.

---



---

**CAUTION:** THIS IS USED TO DRAW THE OPERATOR'S ATTENTION TO INFORMATION, DIRECTIVES, PROCEDURES, ETC. WHICH, IF IGNORED, MAY RESULT IN DAMAGE BEING CAUSED TO THE MATERIAL BEING USED. THE ASSOCIATED TEXT DESCRIBES THE NECESSARY PRECAUTIONS TO TAKE AND THE CONSEQUENCES THAT MAY ARISE IF THE PRECAUTIONS ARE IGNORED.

---



---

**WARNING!** **THIS INTRODUCES DIRECTIVES, PROCEDURES, PRECAUTIONARY MEASURES, ETC. WHICH MUST BE EXECUTED OR FOLLOWED WITH THE UTMOST CARE AND ATTENTION, OTHERWISE THE PERSONAL SAFETY OF THE OPERATOR OR THIRD PARTY MAY BE PUT AT RISK. THE READER MUST ABSOLUTELY TAKE NOTE OF THE ACCOMPANYING TEXT, AND ACT UPON IT, BEFORE PROCEEDING FURTHER.**

---

---

# 1. Introduction

---

## 1.1 UNPACKING YOUR 3410 TORQUE DISPLAY

Your 3410 Torque Display was packaged in reusable, shock resistant packing material that will protect the instrument during normal handling.

1. Make sure the carton contains the following:

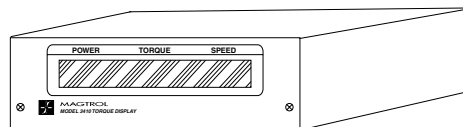

3410 Torque Display

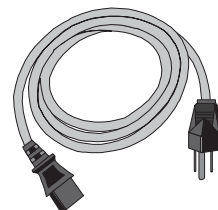

Line cord

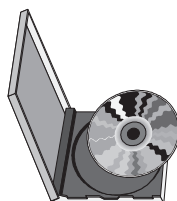

Magtrol  
User Manual  
CD-Rom

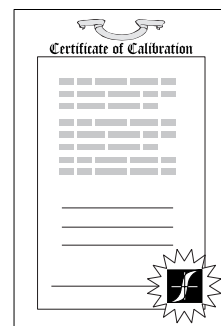

Calibration Certificate

2. Inspect the contents for any evidence of damage in shipping. In the event of shipping damage, immediately notify the carrier and Magtrol's Customer Service Department.



---

Note: Save all shipping cartons and packaging material for reuse when returning the instrument for calibration or servicing.

---

## 1.2 FEATURES OF THE 3410 TORQUE DISPLAY

Designed specifically for use with Magtrol's TM In-Line Torque Transducers and TF Torque Flange Sensors, the Model 3410 Torque Display powers the transducer and utilizes high-speed digital signal processing to display torque, speed and mechanical power. Its features include:

- High Quality, Easy-to-Read Display: Vacuum fluorescent readout.
- Isolated RS-232 Interface: Eliminates system ground loops.
- Torque Measurement Options: Standard English, metric and SI settings.
- Closed-Box Calibration of Torque: Eliminates need to open box for adjustments.
- Speed and Torque Outputs

**1.3 DATA SHEET**

# Model 3410 Torque Display

## FEATURES

- For use with all Magtrol TM / TMHS / TMB In-Line Torque Transducers and TF Torque Flange Sensors
- High Quality, Easy-to-Read Vacuum Fluorescent Readout: Displays torque, speed and power
- Adjustable English, Metric and SI Torque Units
- Isolated RS-232 Interface
- Torque and Speed Outputs
- BITE: Built-In Test Equipment
- Overload Indication
- Tare Function
- Closed Box Calibration
- Includes Magtrol Torque 1.0 Software



## DESCRIPTION

Magtrol’s Model 3410 Torque Display is designed for use with all TM, TMHS, TMB and TF Torque Transducers. This easy-to-use device powers the transducer and utilizes high speed Digital Signal Processing (DSP) to display torque, speed and mechanical power. It includes a tare function to help offset any slight residuals caused by couplings or suspended loads. The 3410 may also be used with sensors requiring 24 V DC power (400 mA max.) and have  $\pm 5$  VDC torque output ( $\pm 10$  VDC max.) and 3.3 VHC speed output.

## TORQUE 1.0 SOFTWARE

Magtrol’s Torque 1.0 Software is a user-friendly Windows® executable program, used to automatically collect torque, speed and mechanical power data. The data can be printed, displayed graphically or quickly saved as a Microsoft® Excel spreadsheet. Standard features of Torque 1.0 include:

- Measured Parameter vs. Time
- Adjustable Sampling Rates
- Polynomial Curve Fitting
- Peak Torque Capture
- Direction of Rotation
- Multi-Axes Graphing
- Optional USB Interface: for reading up to 4 thermocouples

## SYSTEM CONFIGURATION

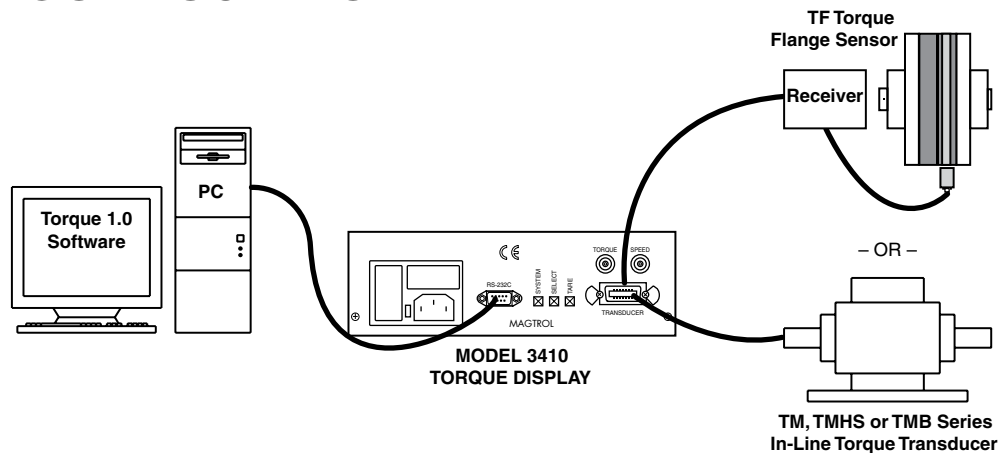

# Specifications

**3410**

MEASUREMENT CHARACTERISTICS	
Maximum Speed / Input Frequency	99,999 rpm / 99,999 Hz
Accuracy	Speed: 0.01% of reading from 5 rpm to 100,000 rpm Torque: 0.01% of range ( $\pm 5$ V)
ELECTRICAL CHARACTERISTICS	
Fuses (5 x 20 mm)	IEC 500 mA 250 V T
Power Requirements	30 VA
Voltage Requirements	120/240 V 60/50 Hz
INPUTS AND OUTPUTS	
Maximum Torque Input	$\pm 10$ VDC
Torque Output BNC	$\pm 10$ VDC (direct from transducer)
Speed Output BNC	3.3 VHC pulse (buffered from transducer)

ENVIRONMENT	
Operating Temperature	5 °C to 40 °C
Relative Humidity	< 80%
Temperature Coefficient	0.001% (5 °C to 50 °C) of FS/°C
DIMENSIONS	
Width	9.88 in 251 mm
Height	2.80 in 71 mm
Depth	7.49 in 190 mm
Weight	2.85 lb 1.28 kg

## FRONT PANEL

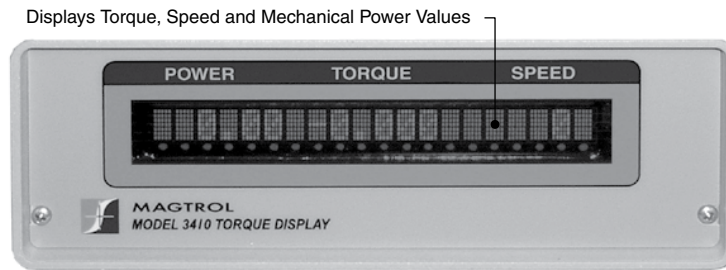

## REAR PANEL

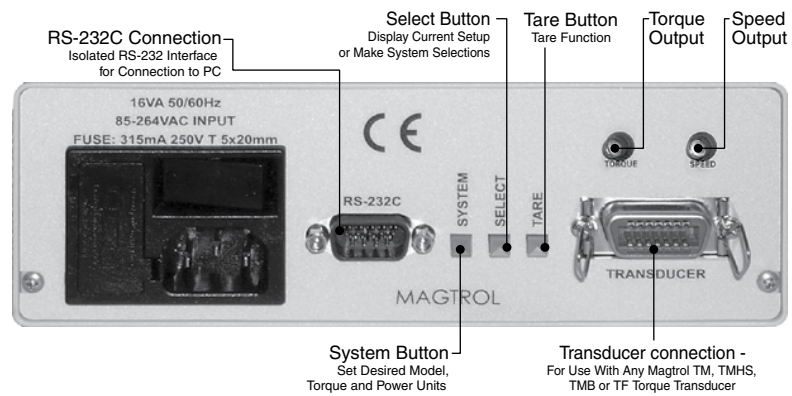

## ACCESSORIES

Description	Model/Part #
TM / TMHS / TMB In-Line Torque Transducer Connector Cable, 5 m	ER 113-01
TM / TMHS / TMB In-Line Torque Transducer Connector Cable, 10 m	ER 113-02
TM / TMHS / TMB In-Line Torque Transducer Connector Cable, 20m	ER 113-03
TF Flange Torque Transducer Connector Cable, 5 m	ER 116-01
TF Flange Torque Transducer Connector Cable, 10 m	ER 116-02
TF Flange Torque Transducer Connector Cable, 20m	ER 116-03

*Due to the continual development of our products, we reserve the right to modify specifications without forewarning.*

---

## 2. Controls

---

### 2.1 FRONT PANEL

The front panel contains a Vacuum Fluorescent Display (VFD) that provides information about the control functions and torque transduce.

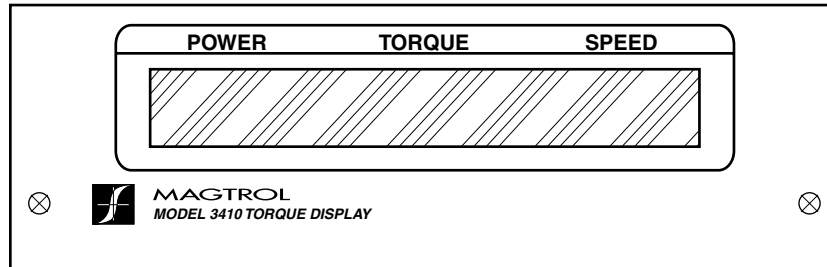

Figure 2-1 Front Panel

The displays from left to right are:

- POWER
- TORQUE
- SPEED
- Overload Indicator: If the inputs exceed the range of the instrument, “-OL-” will appear in the TORQUE or SPEED portion of the display. Once the condition has cleared, the unit will automatically return to the main menu.

## 2.2 REAR PANEL

The rear panel provides connectors and receptacles for connecting to appropriate equipment along with a power switch and 3 control buttons.

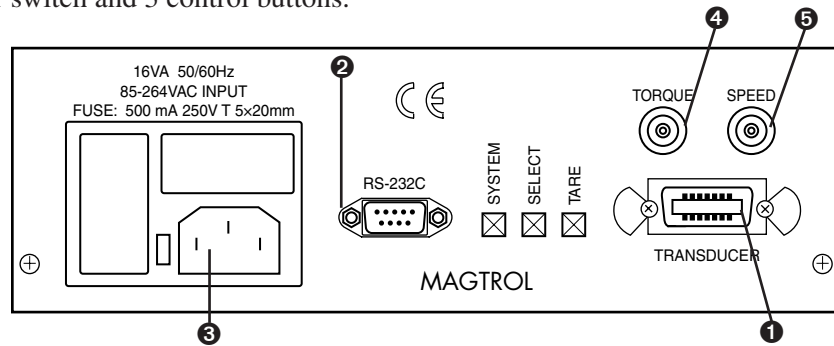
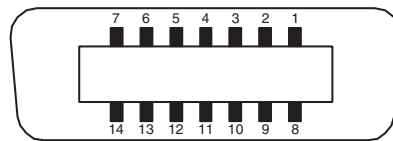

Figure 2–2 Rear Panel

### 2.2.1 REAR PANEL INPUTS AND OUTPUTS

**1** TRANSDUCER      Connect transducer signal cable here.



- |                |                         |
|----------------|-------------------------|
| 1. N/C         | 8. 5 V COM              |
| 2. N/C         | 9. ROTATIONAL DIRECTION |
| 3. +24 VDC     | 10. SPEED               |
| 4. +24 VDC COM | 11. N/C                 |
| 5. +24 VDC COM | 12. BITE                |
| 6. N/C         | 13. TORQUE COMMON       |
| 7. 5 V OUT     | 14. TORQUE SIGNAL       |

Figure 2–3 Transducer Connector

**2** RS-232C      Isolated RS-232 Connector

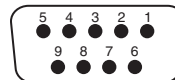

- |        |    |
|--------|----|
| 1.     | 6. |
| 2. TX  | 7. |
| 3. RX  | 8. |
| 4.     | 9. |
| 5. GND |    |

Figure 2–4 RS-232C Interface

**3** POWER      Attach IEC approved power cord here.

**4** TORQUE      Torque Output: Connect to data acquisition system here.

**5** SPEED      Speed Output: Connect to data acquisition system here.

## 2.2.2 REAR PANEL CONTROLS AND BUTTONS

The rear panel controls and buttons, from left to right, are:

- Power switch
- System button
- Select button
- Tare button

The following table provides a quick reference on how to use each button. For more detailed information refer to *Chapter 4 – Manually Controlled Operation*.

Button	To Use	Function
POWER	Press I to turn power ON. Press O to turn power OFF.	Turns power ON or OFF.
SYSTEM	Press.	Enables setup of torque measuring device, transducer model, torque units, power units and display contrast settings.
SELECT	During SYSTEM setup, press and release. During normal operation, press and hold button.	During SYSTEM setup, scrolls through available torque measuring device, transducer model, torque unit, power unit and display contrast setting options. During normal operation, displays current setup.
TARE	Press.	Sets the current A/D reading as the offset value during calculations.

# 3. Installation/Configuration



Note: Before installing the 3410, you should become familiar with the front and rear panels, as outlined in *Chapter 2—Controls*.

## 3.1 POWERING UP THE 3410



Note: To reduce the risk of electric shock, the case of the 3410 is earth grounded.

### 3.1.1 LINE VOLTAGE

The 3410 will operate with either of the following power sources without any modifications:

- 120 V 50/60 Hz
- 240 V 50/60 Hz

### 3.1.2 SELF-TEST



Note: To make sure that the 3410 is operational, a Magtrol torque sensor must be installed and connected to the 3410.

1. Connect the 3410 to the torque transducer using a 14-pin to 6-pin signal cable.

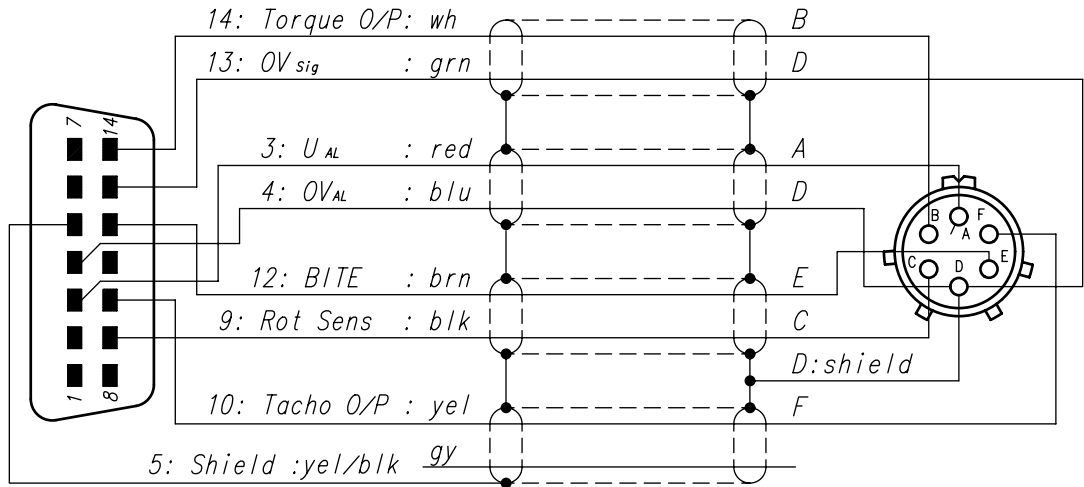

Figure 3-1 Cable and Connection Diagrams

2. Turn on the power to the 3410. The Title Display will appear.

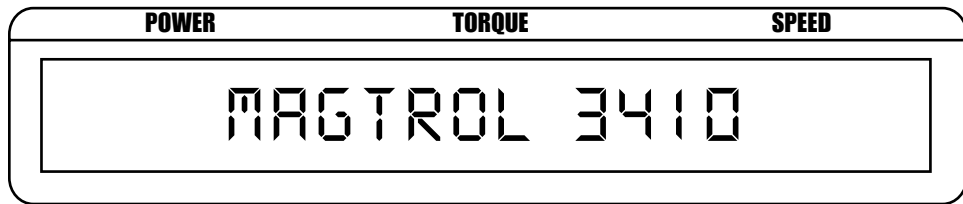

Figure 3-2 Title Display

Then an additional display will appear indicating the version of your Magtrol 3410 Torque Display.

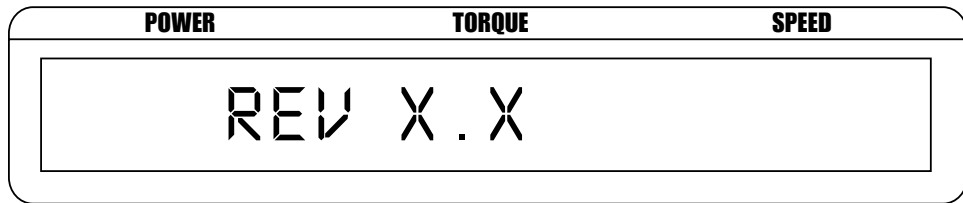

Figure 3-3 Revision Display

### 3.1.3 MAIN MENU

When the 3410 is completely powered up and ready for use, the Main Menu will appear on the display.



Figure 3-4 Main Menu

SETUP

---

# 4. Manually Controlled Operation

---

## 4.1 SETTING DESIRED OPERATING PARAMETERS

### 4.1.1 DEVICE SETUP

Selects the type of torque measuring device connected to the 3410 Display. Options include:

- TM(HS) 200
- TMB 200
- TM(HS) 300
- TMB 300
- TF 200
- SPECIAL

1. Press and release SYSTEM button once. The System Display will flash momentarily.

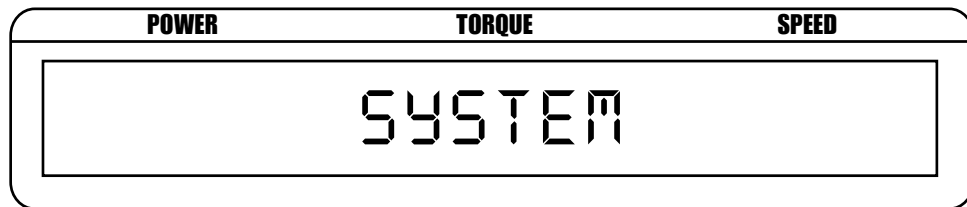

Figure 4-1 System Display

Then the Device Setup Menu will appear.

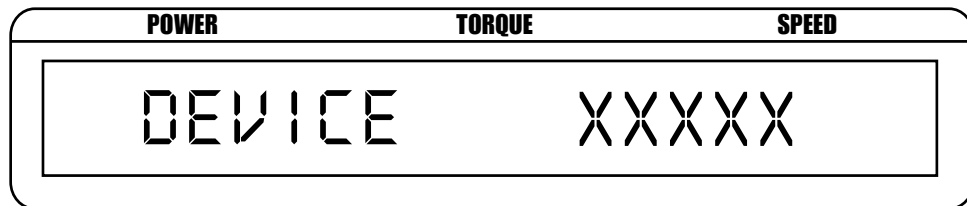

Figure 4-2 Device Setup Menu

2. Press and release SELECT button until desired torque measuring device appears in display.
3. Press and release SYSTEM button 5 times. The Saving System Display will flash momentarily.

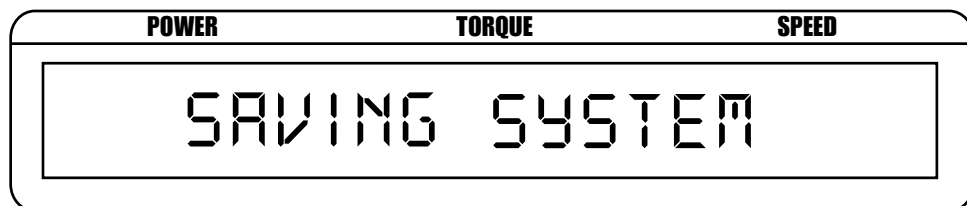

Figure 4-3 Saving System Display

Then the display will return to the Main Menu.

### 4.1.2 MODEL SELECTION

Selects the specific torque transducer model. Options include:

TM / TMHS 200 Series	TMB 200 Series	TM / TMHS 300 Series	TMB 300 Series	TF 200 Series
---	---	TM 301	---	---
---	---	TM 302	---	---
---	---	TM(HS) 303	TMB 303	---
TM(HS) 204	TMB 204	TM(HS) 304	TMB 304	---
TM(HS) 205	TMB 205	TM(HS) 305	TMB 305	TF 205
TM(HS) 206	TMB 206	TM(HS) 306	TMB 306	---
TM(HS) 207	TMB 207	TM(HS) 307	TMB 307	---
TM(HS) 208	TMB 208	TM(HS) 308	TMB 308	---
TM(HS) 209	TMB 209	TM(HS) 309	TMB 309	TF 209
TM(HS) 210	TMB 210	TM(HS) 310	TMB 310	TF 210
TM(HS) 211	TMB 211	TM(HS) 311	TMB 311	TF 211
TM(HS) 212	TMB 212	TM(HS) 312	TMB 312	TF 212
TM(HS) 213	TMB 213	TM(HS) 313	TMB 313	TF 213
TM(HS) 214	---	TM(HS) 314	---	TF 214
TM(HS) 215	---	TM(HS) 315	---	TF 215
TM(HS) 216	---	TM(HS) 316	---	TF 216
TM(HS) 217	---	TM(HS) 317	---	TF 217
---	---	---	---	TF 218
---	---	---	---	TF 219
---	---	---	---	TF 220

1. Press and release SYSTEM button 2 times. The Model Selection Menu will appear.

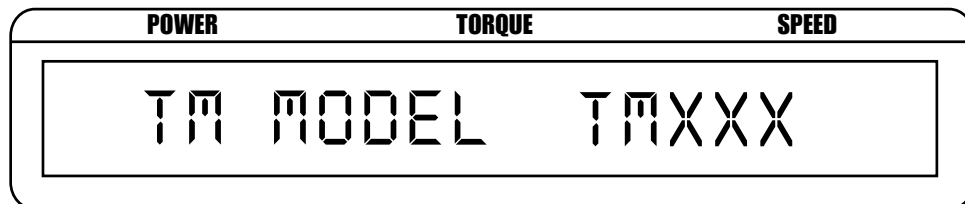

Figure 4-4 Model Selection Menu

2. Press and release SELECT button until desired torque transducer model appears in display.
3. Press and release SYSTEM button 4 times. The Saving System Display will flash momentarily and the unit will automatically return to the Main Menu.

### 4.1.3 TORQUE UNITS SETUP

Selects the desired unit of measure that corresponds with the values displayed. Options include:

- oz·in
- oz·ft
- lb·in
- lb·ft
- g·cm
- kg·cm
- mN·m
- cN·m
- N·m
- daN·m
- kN·m

1. Press and release SYSTEM button 3 times. The Torque Units Setup Menu will appear.

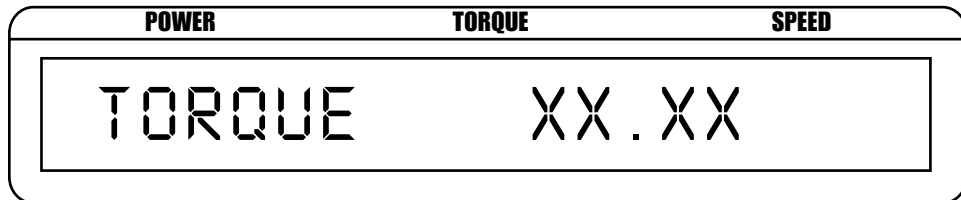

Figure 4-5 Torque Units Setup Menu

2. Press and release SELECT button until the desired unit of measure is displayed.
3. Press and release SYSTEM button 3 times. The Saving System Display will flash momentarily and the unit will automatically return to the Main Menu.

### 4.1.4 POWER UNITS SETUP

Selects the desired unit of power that corresponds with the values displayed. Options include:

- watts
- kW
- hp

1. Press and release SYSTEM button 4 times. The Power Units Setup Menu will appear.

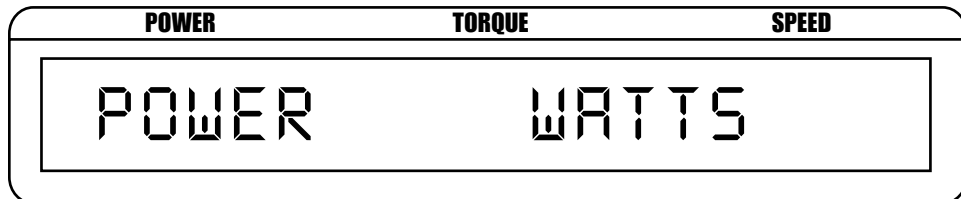

Figure 4-6 Power Units Setup Menu

2. Press and release SELECT button until the desired unit of power is displayed.
3. Press and release SYSTEM button 2 times. The Saving System Display will flash momentarily and the unit will automatically return to the Main Menu.

#### 4.1.5 CONTRAST SETUP

The 3410 is shipped with the Contrast programmed to the lowest setting in order to prolong display life. If it is necessary to increase the Contrast for improved readability, execute the following steps:

1. Press and release SYSTEM button 5 times. The display appears as follows:

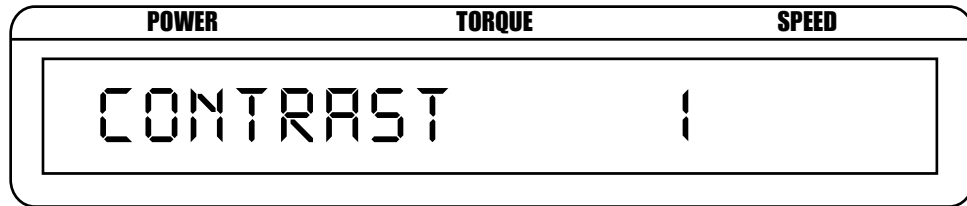

Figure 4-7 Contrast Setup Menu

2. Press and release SELECT button until desired brightness is reached (select from a range of 1 to 3).
3. Press and release SYSTEM button once. The Saving System Display will flash momentarily and the unit will automatically return to the Main Menu.

#### 4.1.6 SYSTEM SETUP CHECK

1. To check and make sure that all parameters have been set properly, press and hold SELECT button.

Example: When testing a TM 314 (which has a 60-bit encoder), with power units expressed in watts and torque units expressed in oz.ft, the System Check Display will appear as follows:

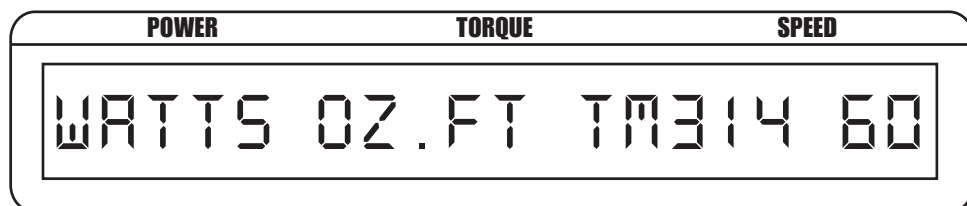

Figure 4-8 System Check Display Example

2. When the SELECT button has been released, the unit will automatically return to the Main Menu.

**4.1.7 TARE FUNCTION**

The calibrated offset of the 3410 may be changed using the tare function. To set:

1. Press TARE button.
2. Display will flash “TARE” and the unit will take the current value of the torque input and make it the new zero.



---

Note: In order to reset the tare value, the power to the unit must be turned OFF.

---

**4.1.8 BITE FUNCTION**

Built-In Test Equipment (BITE) has been programmed into the 3410 in order to test the system and make sure all devices are connected and running properly. When the BITE function is activated the software will turn on an NPN transistor internal to the 3410 that is in an open collector configuration. This output, or collector, is found on pin 12 of the 14-pin connector on the back of the unit. This signal is routed to the transducer and will activate internal circuitry to output a test signal. In the case of a TM series transducer, the output will be 5 volts (full scale) in addition to any offset value. As for the TF series, the output will be about 4 volts (about 80% of full scale) in addition to any offset value. To activate:

1. Press SELECT and TARE buttons simultaneously.
2. The display will flash “BITE”, then provide the full-scale voltage at the input of the unit.

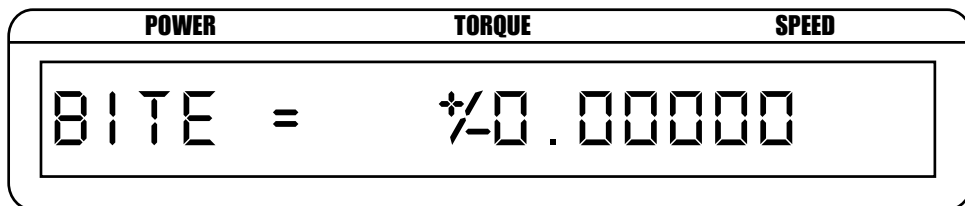

Figure 4–9 BITE Display

3. After 5 seconds, the display automatically returns to the Main Menu.

# 5. Computer Controlled Operation

The 3410 Torque Display can be used with a personal computer for standard or custom torque and encoder setups. Using the 3410 with a computer enables the unit to perform at its full capacity.

## 5.1 ABOUT THE RS-232 INTERFACE

The 3410 is equipped with an Isolated RS-232 (serial) interface that communicates with the host computer through a DB-9 interface connector. The connector pin-out consists of 2-TX, 3-RX and 5-GND.

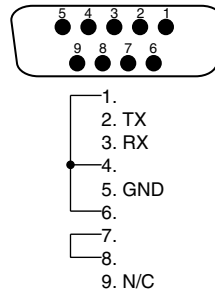

Figure 5-1 RS-232 Interface

### 5.1.1 CONNECTION

The RS-232 connection includes null modem wiring internal to the unit. To install, use a straight through pin-to-pin connector cable, which can be purchased from you local electronics store.

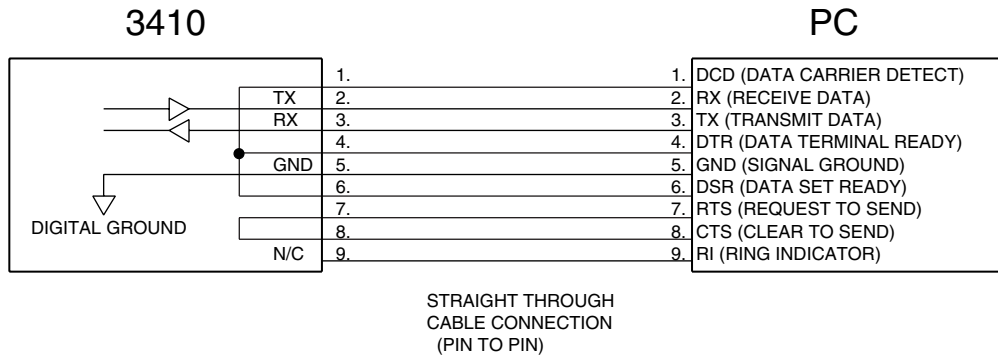

Figure 5-2 Cable Connection

### 5.1.2 COMMUNICATION PARAMETERS

- Default Baud Rate - 115200
- No parity
- 8 data bits
- 1 stop bit

## 5.2 3410 COMMAND SET

When entering a command code:

1. Type all characters in uppercase ASCII format.
2. End all commands with a CR-LF (hex 0D-0A).
3. Do not string multiple commands together in one line.

The character # represents a floating-point numerical value following the command. Leading zeroes are not required.



Note: If a command is not recognized, a COMMAND ERROR CR-LF string return will occur accompanied by a beep.

### 5.2.1 COMMUNICATION COMMANDS

Command Code	Function	Explanation
*IDN?	Returns Magtrol identification and software revision.	---
OD	Prompts to return speed-torque-direction data string.	Output Data prompt to return data string with this format: SxxxxTxxxxxRcrLf or SxxxxTxxxxxLcrLf R or L is the shaft direction indicator, as viewed looking at the dynamometer shaft where: R = right; clockwise (CW) L = left; counterclockwise (CCW) The speed will equal the displayed value and the torque will be in the same units as displayed on the front panel.

### 5.2.2 SETUP COMMANDS

Command Code	Function	Explanation
BITE	Activates built-in test function.	The display will flash “BITE”, then provide the full-scale voltage at the input of the unit. After 5 seconds, the display automatically returns to the Main Menu.
M1	Enables rear panel controls.	Use this command to enable rear panel control of most functions.
M0	Locks out rear panel controls.	Use this command to lock out the rear panel controls, so that the Torque Display settings can be changed only by using the computer with RS-232 interface.
TR	Resets Tare.	Resets tare to 0 (zero).
TS	Sets Tare.	Reads current torque and uses as tare value.

OPERATION

Command Code	Function	Explanation
UD#	Sets attached device.	Values for # are: 0 = TM(HS) 2XX 1 = TMB 2XX 2 = TM(HS) 3XX 3 = TMB 3XX 4 = TF 2XX 5 = SPECIAL
UE#	Sets encoder units to # when device = SPECIAL (UD5).	# = 1 to 6000 Programmed value # is not saved at power down.
UI#	Selects model.	For measurements to be accurate, the correct transducer model must be specified. <b>Note:</b> Refer to table in Section 5.2.2.1 for list of models and corresponding values. Programmed value # is not saved at power down.
UR#	Sets display torque units to #.	Values for # are: 0 = oz·in            6 = mN·m 1 = oz·ft            7 = cN·m 2 = lb·in            8 = N·m 3 = lb·ft            9 = kN·m 4 = g·cm            10 = daN·m 5 = kg·cm Torque unit conversion defaults to 0 (oz·in) if out of range. Programmed value # is not saved at power down.
UT#	Sets torque scale to # when device = SPECIAL (UD5).	# = 0 to 100,000 Programmed value # is not saved at power down.
SAVE	Saves setup.	Saves values programmed via serial port.

## 5.2.2.1 Transducer Model Codes

UI Value for #	UD = 0	UD = 1	UD = 2		UD = 3	UD = 4
			REV 1.2	REV 1.3		
0	TM(HS) 204	TMB 204	TM(HS) 303	TM 301	TMB 303	TF 205
1	TM(HS) 205	TMB 205	TM(HS) 304	TM 302	TMB 304	TF 209
2	TM(HS) 206	TMB 206	TM(HS) 305	TM(HS) 303	TMB 305	TF 210
3	TM(HS) 207	TMB 207	TM(HS) 306	TM(HS) 304	TMB 306	TF 211
4	TM(HS) 208	TMB 208	TM(HS) 307	TM(HS) 305	TMB 307	TF 212
5	TM(HS) 209	TMB 209	TM(HS) 308	TM(HS) 306	TMB 308	TF 213
6	TM(HS) 210	TMB 210	TM(HS) 309	TM(HS) 307	TMB 309	TF 214
7	TM(HS) 211	TMB 211	TM(HS) 310	TM(HS) 308	TMB 310	TF 215
8	TM(HS) 212	TMB 212	TM(HS) 311	TM(HS) 309	TMB 311	TF 216
9	TM(HS) 213	TMB 213	TM(HS) 312	TM(HS) 310	TMB 312	TF 217
10	TM(HS) 214	N/A	TM(HS) 313	TM(HS) 311	TMB 313	TF 218
11	TM(HS) 215	N/A	TM(HS) 314	TM(HS) 312	N/A	TF 219
12	TM(HS) 216	N/A	TM(HS) 315	TM(HS) 313	N/A	TF 220
13	TM(HS) 217	N/A	TM(HS) 316	TM(HS) 314	N/A	N/A
14	N/A	N/A	TM(HS) 317	TM(HS) 315	N/A	N/A
15	N/A	N/A	N/A	TM(HS) 316	N/A	N/A
16	N/A	N/A	N/A	TM(HS) 317	N/A	N/A
17	N/A	N/A	N/A	N/A	N/A	N/A

## 5.3

## CALIBRATION COMMANDS

Command Code	Function	Explanation
CAL	Sets unit into calibrate.	See <i>Chapter 6 - Calibration.</i>
ZERO	Sets the offset to the value at the input.	See <i>Chapter 6 - Calibration.</i>
FS#	Calibrate full scale to this value.	# = the value at input

---

# 6. Calibration

---

## 6.1 CLOSED-BOX CALIBRATION

The 3410 features closed-box calibration. The advantage of closed-box calibration is that the user does not have to disassemble the case or make mechanical adjustments.

The torque readout can be calibrated using external reference sources. Correction factors for offset and gain are stored in nonvolatile memory. They remain in effect until the user or the calibration house updates them.

## 6.2 CALIBRATION SCHEDULE

Calibrate the 3410:

- After any repairs are performed.
- At least once a year; more frequently to ensure required accuracy.

## 6.3 BASIC CALIBRATION PROCESS

The basic calibration process consists of two procedures which must be performed in the following order:

1. Initial Procedure
2. Torque Offset and Gain (computer)

Items needed for calibrating the 3410:

- External voltage reference of 0 to 10 volts DC
- Digital multimeter (DMM)

Both instruments should have a VDC accuracy of 0.005% or better.

### 6.3.1 INITIAL CALIBRATION PROCEDURE

1. Allow the 3410 to stabilize in an environment with:
  - An ambient temperature of 18°C to 25°C.
  - Relative humidity less than 80%.
2. Turn on the 3410.
3. Allow the 3410 to warm up for at least 30 minutes.

### 6.3.2 TORQUE OFFSET AND GAIN

1. Send the command CAL to the unit via the serial port.
2. The response will be ZERO.
3. Apply 0.0000 volts to the input.
4. Send the command ZERO.
5. The response will be FS=X.XXXX
6. Apply 5.0000 volts to the input (this can vary a few mV but measure accurately.)
7. Send the command FS=X.XXXX (where X.XXXX is your meter reading).
8. The response will be CAL COMPLETE.

---

## 7. Troubleshooting

---

<b>Problem</b>	<b>Reason</b>	<b>Solution</b>
Returned data indicates COMMAND ERROR.	Command does not match the unit's programmed set of instructions.	Use correct command and format.
Mechanical power reads much higher or lower than expected.	Torque units or scale factor is incorrect.	Set torque input units and scale factor to match the specifications of torque transducer.
No RS-232 communication.	Setup error and/or hardware fault.	Check: <ul style="list-style-type: none"><li>• Baud rate of Torque Transducer Display</li><li>• Pinout of serial cable</li><li>• Cable attachment to Torque Display and serial interface port of computer</li></ul>

If you require additional assistance, please contact Magtrol Customer Service at 1-716-668-5555.



---

# Glossary

---

Following is a list of abbreviations and terms used in this manual.

- CR** ..... carriage return
- DMM** ..... digital multimeter
- DSP** ..... Digital Signal Processing
- hp** ..... horsepower; measure of mechanical power
- Hz** ..... Hertz; frequency
- I/O** ..... input/output
- LF** ..... line feed
- local** ..... manual control (use front panel controls)
- PC** ..... personal computer
- remote** ..... computer control (uses programmed controls from personal computer)
- rpm** ..... revolutions per minute
- RS-232** ..... Recommended Standard-232C, a standard interface approved by the Electronic Industries Association (EIA) for connecting serial devices.
- SI** ..... Systeme Internationale units of measure
- V** ..... volts; typically AC
- VDC** ..... volts DC

---

# Index

---

78P205 Board 20

## B

BITE 13. *See* Built-In Test Equipment

Built-In Test Equipment 13

Buttons 6

## C

Calibration 18

    Procedure 18

    Schedule 18

Calibration Commands 17

Closed-Box Calibration 18

Command Set 15–17

Commands

    Calibration 17

    Communication 15

    Setup 15

Communication Commands 15

Communication Parameters 14

Connection 7

    RS-232 14

Contrast

    Setup 12

Controls 6

## D

Data Sheet 2

Device Setup 9

## F

Features 1

Front Panel 4

Functions. *See also* Controls and Buttons

## G

Gain

    Torque 18

## I

Inputs 5. *See also* Outputs

## L

Line Voltage 7

## M

Main Menu 8

Menus

    Contrast Setup 12

    Main 8

    Power Units Setup 11

    Torque Units Setup 11

Model Selection 10

## O

Offset

    Torque 18

Outputs 5. *See also* Inputs

    Speed 5

    Torque 5

## P

Parameters 9

    Communication 14

Power Cord 5

Power Units

    Setup 11

    Setup Menu 11

## R

Rear Panel 5

RS-232C 5

    Connection 14

    Interface 14

## S

Schematics

    78P205 Board 20

Self-Test 7

Setup

    Contrast 12

    Device 9

    Model 10

    Power Units 11

    Torque Units 11

Setup Check 12

Setup Commands 15

SPEED 5

System Setup Check 12

## T

Tare 13

TORQUE 5

Torque Offset and Gain 18

Torque Units

    Setup 11

    Setup Menu 11

Transducer Connector 5

Troubleshooting 19

## U

Unpacking 1

## V

Vacuum Fluorescent Display 4

VFD. *See* Vacuum Fluorescent Display

---

# Service Information

---

## RETURNING MAGTROL EQUIPMENT FOR REPAIR AND/OR CALIBRATION

Before returning equipment to Magtrol for repair and/or calibration, please visit Magtrol's Web site at <http://www.magtrol.com/support/rma.htm> to begin the Return Material Authorization (RMA) process. Depending on where the equipment is located and which unit(s) will be returned, you will be directed to either ship your equipment back to Magtrol, Inc. in the United States or Magtrol SA in Switzerland.

### Returning Equipment to Magtrol, Inc. (United States)

When returning equipment to Magtrol, Inc.'s factory in the United States for repair and/or calibration, a completed Return Material Authorization (RMA) form is required.

1. Visit Magtrol's Web site at <http://www.magtrol.com/support/rma.htm> to begin the RMA process.
2. Complete the RMA form online and submit.
3. An RMA number will be issued to you via e-mail. Include this number on all return documentation.
4. Ship your equipment to:  
MAGTROL, INC.  
70 Gardenville Parkway  
Buffalo, NY 14224  
Attn: Repair Department
5. After Magtrol's Repair Department receives and analyzes your equipment, a quotation listing all the necessary parts and labor costs, if any, will be faxed or e-mailed to you.
6. After receiving your repair estimate, provide Magtrol with a P.O. number as soon as possible. A purchase order confirming the cost quoted is required before your equipment can be returned.

### Returning Equipment to Magtrol SA (Switzerland)

If you are directed to ship your equipment to Switzerland, no RMA form/number is required. Just send your equipment directly to Magtrol SA in Switzerland and follow these shipment instructions:

1. Ship your equipment to:  
MAGTROL SA  
After Sales Service  
Route de Montena 77  
1728 Rossens / Fribourg  
Switzerland  
VAT No: 485 572
2. Please use our forwarder : TNT • 1-800-558-5555 • Account No 154033  
Only ship ECONOMIC way (3 days max. within Europe)
3. Include the following documents with your equipment:
  - Delivery note with Magtrol SA's address (as listed above)
  - Three pro forma invoices with:
    - Your VAT number
    - Description of returned goods
    - Noticed failures
    - Value - for customs purposes only
    - Origin of the goods (in general, Switzerland)
4. A cost estimate for repair will be sent to you as soon as the goods have been analyzed. If the repair charges do not exceed 25% the price of a new unit, the repair or calibration will be completed without requiring prior customer authorization.



*Testing, Measurement and Control of Torque-Speed-Power • Load-Force-Weight • Tension • Displacement*

[www.magtrol.com](http://www.magtrol.com)

**MAGTROL INC**

70 Gardenville Parkway  
Buffalo, New York 14224 USA  
Phone: +1 716 668 5555  
Fax: +1 716 668 8705  
E-mail: [magtrol@magtrol.com](mailto:magtrol@magtrol.com)

**MAGTROL SA**

Route de Montena 77  
1728 Rossens/Fribourg, Switzerland  
Phone: +41 (0)26 407 3000  
Fax: +41 (0)26 407 3001  
E-mail: [magtrol@magtrol.ch](mailto:magtrol@magtrol.ch)

**Subsidiaries in:**

Germany • France  
China • India

Worldwide Network  
of Sales Agents

