

MAGTROL

HD-1/HD-2 Series

Dial Weight Dynamometers



User's Manual

Purchase Record

Please record all model numbers and serial numbers of your Magtrol equipment, along with the general purchase information. The model number and serial number can be found on either a silver identification plate or white label affixed to each unit. Refer to these numbers whenever you communicate with a Magtrol representative about this equipment.

Model Number: _____

Serial Number: _____

Purchase Date: _____

Purchased From: _____

While every precaution has been exercised in the compilation of this document to ensure the accuracy of its contents, Magtrol, Inc. assumes no responsibility for errors or omissions. Additionally, no liability is assumed for any damages that may result from the use of the information contained within this publication.

COPYRIGHT

Copyright ©1999-2008 Magtrol, Inc. All rights reserved.

Copying or reproduction of all or any part of the contents of this manual without the express permission of Magtrol is strictly prohibited.

Revisions To This Manual

The contents of this manual are subject to change without prior notice. Should revisions be necessary, updates to all Magtrol User's Manuals can be found at Magtrol's web site at www.magtrol.com/support/manuals.htm.

Please compare the date of this manual with the revision date on the web site, then refer to the manual's Table of Revisions for any changes/updates that have been made since this edition.

REVISION DATE

1st Edition, Revision B – August 2008

TABLE OF REVISIONS

Date	Edition	Change	Section(s)
12/18/08	1st Edition, Rev. B	All dynamometers are now shipped with a speed pickup, 2-pin, and 14-pin cable.	4.1
12/18/08	1st Edition, Rev. B	The Model 5400 Tachometer was replaced with the Model 3410 Torque Display as the primary speed readout option.	2.3.1
08/01/06	1st Edition, Rev. A	Redesigned manual to be consistent with Magtrol format.	all
12/1999	1st Edition	First PDF version.	---

Table of Contents

REVISIONS TO THIS MANUAL	I
REVISION DATE.....	I
TABLE OF REVISIONS.....	I
TABLE OF CONTENTS	II
TABLE OF FIGURES	III
1. INTRODUCTION	1
1.1 UNPACKING YOUR DIAL WEIGHT DYNAMOMETER.....	1
1.2 TECHNICAL SPECIFICATIONS	1
1.2.1 HYSTERESIS BRAKE CONTROL POWER.....	1
2. INSTALLATION/CONFIGURATION.....	2
2.1 COUNTER WEIGHTS	2
2.2 DYNAMOMETER LEVELING	2
2.3 SYSTEM CONFIGURATION.....	2
2.3.1 SPEED READOUTS	2
2.3.2 POWER SUPPLIES.....	2
2.3.3 CONNECTIONS.....	3
2.4 INITIAL CHECKOUT.....	3
3. TESTING CONSIDERATIONS	4
3.1 SAFETY	4
3.2 ACCURACY	4
3.2.1 TORQUE SCALE GRADUATIONS.....	5
3.3 POWER DISSIPATION	5
3.3.1 POWER ABSORPTION CURVES.....	5
3.4 FIXTURES AND COUPLINGS	9
3.5 WINDAGE	10
3.6 FRICTION.....	10
3.7 VIBRATION.....	11
3.8 COGGING.....	11
3.9 EDDY CURRENTS	12
3.10TEMPERATURE RISE.....	12
4. OPERATING PRINCIPLES.....	13
4.1 SPEED.....	13
4.2 TORQUE.....	13
4.2.1 TORQUE STABILITY	13
5. CALIBRATION	14
5.1 CALIBRATION PREPARATION.....	14
5.2 CALIBRATION PROCEDURE.....	14

TABLE OF FIGURES

2. INSTALLATION/CONFIGURATION	
<i>Figure 2-1 Torque Scale</i>	2
3. TESTING CONSIDERATIONS	
<i>Figure 3-1 Dynamometer Side View</i>	6
<i>Figure 3-2 HD-106-1 Power Absorption Curve</i>	6
<i>Figure 3-3 HD-400-1/2 Power Absorption Curve</i>	7
<i>Figure 3-4 HD-500-1 Power Absorption Curve</i>	7
<i>Figure 3-5 HD-600-1 Power Absorption Curve</i>	8
<i>Figure 3-6 HD-700-1 Power Absorption Curve</i>	8
<i>Figure 3-7 HD-705-1 Power Absorption Curve</i>	9
<i>Figure 3-8 Examples of Possible Shaft Misalignment</i>	10
<i>Figure 3-9 Hysteresis Brake Cross-Section</i>	11
4. OPERATING PRINCIPLES	
<i>Figure 4-1 Optical Encoder Circuit</i>	13
5. CALIBRATION	
<i>Figure 5-1 Calibration Setup</i>	14

1. Introduction

1.1 UNPACKING YOUR DIAL WEIGHT DYNAMOMETER

Your Hysteresis Dynamometer was packaged in reusable, shock resistant packing material that will protect the instrument during normal handling.

1. Make sure the carton contains all dynamometer hardware, counter weights, applicable power supplies, User Manual CD-Rom, and any other small items.



Note: The counter weights may be wrapped separately or installed on the brake.

2. Inspect the contents for any evidence of damage in shipping. In the event of shipping damage, immediately notify the carrier and Magtrol's Customer Service Department.



Note: Save all shipping cartons and packaging material for reuse when returning the instrument for calibration or servicing.

1.2 TECHNICAL SPECIFICATIONS

Model	Full Scale Torque						Maximum Speed	Power Ratings	
	Range One		Range Two		Range Three			5 Minutes	Continuous
	<i>oz·in</i>	<i>accuracy</i>	<i>oz·in</i>	<i>accuracy</i>	<i>oz·in</i>	<i>accuracy</i>	<i>rpm</i>	<i>W</i>	<i>W</i>
HD-106-1	0.5	3.5 %	1	2 %	2	1 %	30,000	35	7
HD-400-1	2	2 %	8	2 %	16	1 %	20,000	200	55
HD-400-2	8	2 %	16	1 %	32	1 %	20,000	200	55
HD-500-1	25	2 %	50	1 %	100	1 %	15,000	400	80
HD-600-1	50	1 %	100	1 %	200	1 %	10,000	600	100
HD-700-1	100	1 %	200	1 %	400	1 %	10,000	700	150
HD-705-1	200	1 %	400	1 %	800	1 %	8,000	1400	300

1.2.1 HYSTERESIS BRAKE CONTROL POWER

Hysteresis brakes require direct current for torque control. They will not respond to alternating current above a few Hz. The nominal voltage rating for all Magtrol Hysteresis Brakes is 28 VDC. The following is a listing of the resistance and current for each brake, by dynamometer model.

Model	Resistance	F.S. Current
	Ω	A
HD-106-1	171	0.164
HD-400-1/2	80	0.350
HD-500-1	120	0.233
HD-700-1	80	0.350
HD-705-1	40	0.700

2. Installation/Configuration

2.1 COUNTER WEIGHTS

Begin by installing the dynamometer counter weights that were shipped with your dynamometer. There should be as many counter weights, 2 or 3, as there are torque scales on the dynamometer dial. This total includes the (minimum scale) weight permanently attached to the brake assembly.



Note: The dynamometer brake assembly should swing freely.

2.2 DYNAMOMETER LEVELING

Level the dynamometer base plate in all planes. The bubble level device on the base plate is convenient for front-to-back leveling. For side-to-side adjustment, it is more accurate to level the dynamometer by observing the torque dial for a ZERO reading. It works best to use the most sensitive torque scale, by removing one, or both of the counter weights.

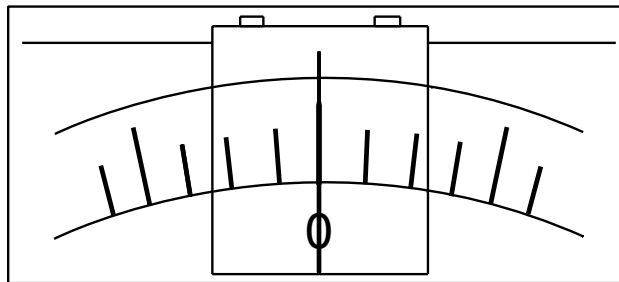

Figure 2-1 Torque Scale



Note: There should be nothing connected to the dynamometer shaft.

2.3 SYSTEM CONFIGURATION

2.3.1 SPEED READOUTS

If an optional speed reading instrument or Model 3410 Torque Display is ordered with the dynamometer, a 14-pin cable for the Torque Display is included.

2.3.2 POWER SUPPLIES

Power supply options for brake control include the Model 5200-2 and the Model 5210-2. The 5200 is unregulated and operates in an “open loop” current control mode; while the 5210 is a current-regulated “closed loop” controller. A 2-pin connection cable is provided with the power supply.

2.3.3 CONNECTIONS

Connect all items together. The dynamometer controller and speed readout (if applicable) interconnections are straight forward using the cord sets.

2.4 INITIAL CHECKOUT

1. Be sure the TORQUE control on the power supply is off (CCW).
2. Turn on the speed readout device (if applicable) and the torque controller.
3. Rotate the dynamometer shaft manually while simultaneously adjusting the TORQUE CONTROL clockwise very slowly.
4. Stop when you begin to feel resistance occurring on the shaft.
5. If there is a speed reading instrument, note the speed (rpm) reading.
6. Return the TORQUE CONTROL to zero.



Note: With the TORQUE CONTROL off, you may notice slight torque pulsations on the shaft. This is normal. For a further description of “salient poles” please refer to *Section 3.8 Cogging*.

3. Testing Considerations

A number of factors must be taken into consideration before running a test including safety, accuracy, power dissipation, fixturing, couplings, windage, friction, vibration, cogging, Eddy currents and temperature rise. The following sections describe these factors, and their effects, in further detail.

3.1 SAFETY



For general safety considerations, please follow these few common-sense rules:

- Be sure that your coupling is adequately rated for the speed and torque that you intend to run.
- Make sure all rotating elements are covered.
- Always wear safety glasses when working around dynamometer test equipment.
- Do not wear loose clothing or ties when working around dynamometer test equipment.
- Never allow anyone to stand close to the side of, or lean over, a rotating shaft coupling.
- Insulate electrical (internal and external) motor connections.



CAUTION: A POWER-LINE FAULT INTO THE DYNAMOMETER FRAME COULD PASS A TRANSIENT SURGE THROUGH ALL INTERCONNECTED INSTRUMENTS, ANY COMPUTER IN USE OR OPERATING PERSONNEL WITH DANGEROUS AND COSTLY CONSEQUENCES!

- Always connect the motor frame to a high current capacity (water pipe) earth ground.
- Be sure the motor control circuit breakers cannot be bypassed by accident. Variable auto-transformers are especially hazardous!
- When operating dynamometers with blowers, hearing protection must be worn.

3.2 ACCURACY

Following, is a list of several factors that affect the apparent accuracy of the torque readout.

- **Coupling Losses:** If the coupling becomes hot to the touch, or if the dynamometer or motor vibrate after a period of running, coupling loss error could occur up to several percent depending on the size of the motor and dynamometer. For more detail, refer to *Section 3.4 – Fixtures and Couplings*.
- **Windage:** Negligible at speeds up to 6000 rpm. This effect is described more extensively in *Section 3.5 – Windage*.



Note: Much of the above is dependent upon motor horsepower, fixturing and other circumstances beyond the control of Magtrol. If reasonable care is exercised, and calibration and maintenance are performed on a regular basis, motor test data accuracy better than 1.5% of torque-speed value can generally be expected.

3.2.1 TORQUE SCALE GRADUATIONS

Some torque scale graduations are more difficult to read (rapidly) than others. What usually works well for most people, is to record torque data points from the easiest reading scale; then correct all data to correspond to the particular range (counterweight) selected, by multiplying (or dividing) by 2 or 4.

3.3 POWER DISSIPATION

All Magtrol Dynamometers are power absorption instruments. As a dynamometer loads a test motor, it absorbs horsepower from the motor into the hysteresis brake. The brake then converts this mechanical energy into heat.

There are finite limits to the amount of energy and resulting temperature rise that any absorption brake can withstand. Rapidly rising operating temperatures from excessive power input can cause severe mechanical distortion of the rotor assembly. This, in turn, may cause the rotating assembly to contact the stationary members that surround it. Once this happens, metal transfer and ultimately seizing of the brake assembly may occur.

Excessive power over extended periods of time may result in more obscure damage including breakdown of bearing lubricants and degradation of magnetic coil insulation.

3.3.1 POWER ABSORPTION CURVES

The following graphs (*Figures 3-1 through 3-6*) represent the maximum power (heat) that the dynamometer can dissipate over time. The specifications shown are conditional upon the following:

- Maximum brake temperature = 100 °C (212 °F)
- Ambient temperature = 25±5 °C (77±9 °F)

The following torque/speed-to-horsepower conversion formulas are provided for your convenience. They are sufficiently accurate (within 1%) to establish horsepower (hp) for use in the heat rise curves.

$$\text{hp} = \text{oz}\cdot\text{in} \times \text{rpm} \times 1.00 \times 10^{-6}$$

$$\text{hp} = \text{lb}\cdot\text{ft} \times \text{rpm} \times 1.90 \times 10^{-4}$$

$$\text{hp} = \text{oz}\cdot\text{ft} \times \text{rpm} \times 1.19 \times 10^{-5}$$

$$\text{hp} = \text{lb}\cdot\text{in} \times \text{rpm} \times 1.59 \times 10^{-5}$$

$$\text{hp} = \text{g}\cdot\text{cm} \times \text{rpm} \times 1.38 \times 10^{-8}$$

$$\text{hp} = \text{N}\cdot\text{m} \times \text{rpm} \times 1.40 \times 10^{-4}$$



Note: Please take a moment to familiarize yourself with any limitations that may apply to your specific dynamometer and motor testing requirements.

The following sketch shows the identifications for shaft height “H” and diameter “D” used in the following specifications.

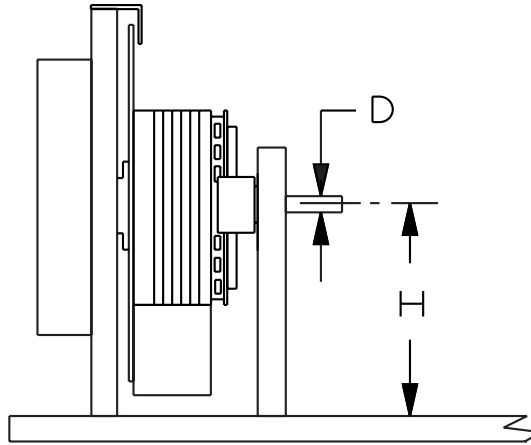

Figure 3-1 Dynamometer Side View

HD-106-1

Shaft Diameter	0.1245 in / 0.1250 in (3.163 mm / 3.175 mm)
Shaft Height	3.50 in (88.9 mm)
Torque Ranges	0.5 oz-in 1.0 oz-in 2.0 oz-in
Input Inertia	7.04×10^{-7} lb-ft-s ²
Maximum Speed	30,000 rpm
Maximum Input Power	40 W

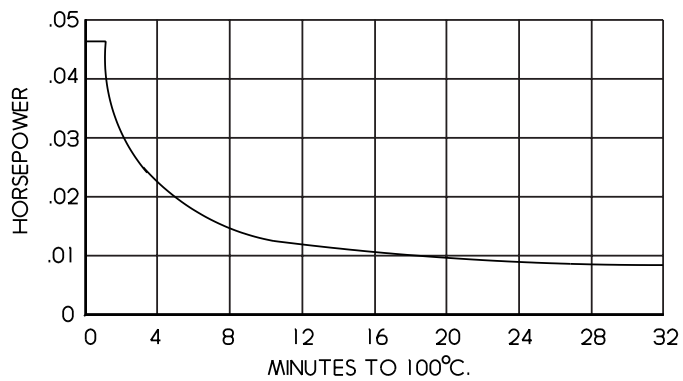

Figure 3-2 HD-106-1 Power Absorption Curve

HD-400-1/2

Shaft Diameter	0.2495 in / 0.2500 in (6.338 mm / 6.350 mm)
Shaft Height	3.50 in (88.9 mm)
Torque Ranges (-1)	2 oz·in 8 oz·in 16 oz·in
Torque Ranges (-2)	8 oz·in 16 oz·in 32 oz·in
Input Inertia	1.55×10^{-5} lb·ft·s ²
Maximum Speed	25,000 rpm
Maximum Input Power	190 W

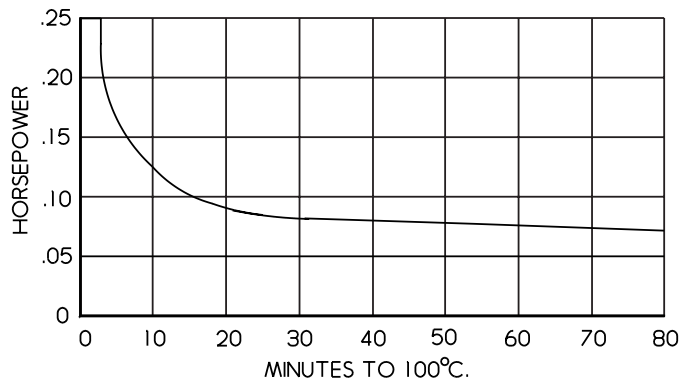

Figure 3-3 HD-400-1/2 Power Absorption Curve

HD-500-1

Shaft Diameter	0.3745 in / 0.3750 in (9.512 mm / 9.525 mm)
Shaft Height	4.00 in (101.6 mm)
Torque Ranges	25 oz·in 50 oz·in 100 oz·in
Input Inertia	8.05×10^{-5} lb·ft·s ²
Maximum Speed	20,000 rpm
Maximum Input Power	375 W

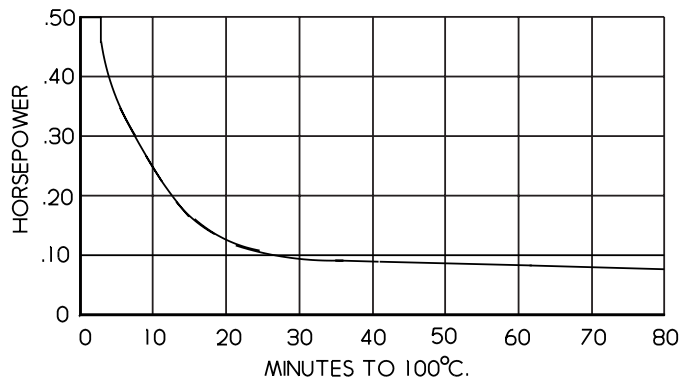

Figure 3-4 HD-500-1 Power Absorption Curve

HD-600-1

Shaft Diameter	0.4995 in / 0.5000 in (12.687 mm / 12.700 mm)
Shaft Height	4.812 in (122.22 mm)
Torque Ranges	50 oz·in 100 oz·in 200 oz·in
Input Inertia	2.34×10^{-5} lb·ft·s ²
Maximum Speed	20,000 rpm
Maximum Input Power	550 W

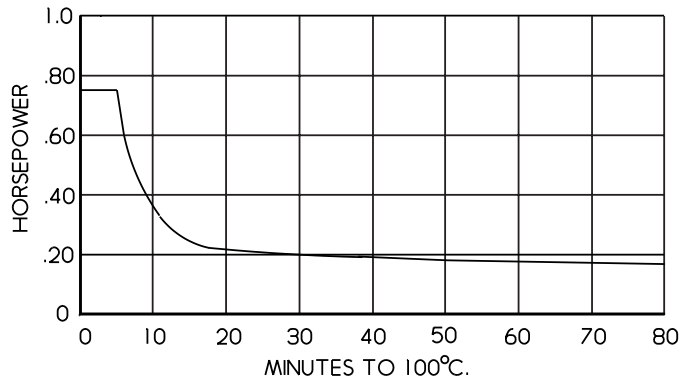

Figure 3-5 HD-600-1 Power Absorption Curve

HD-700-1

Shaft Diameter	0.4995 in / 0.5000 in (12.687 mm / 12.700 mm)
Shaft Height	5.875 in (149.2 mm)
Torque Ranges	100 oz·in 200 oz·in 400 oz·in
Input Inertia	5.51×10^{-4} lb·ft·s ²
Maximum Speed	15,000 rpm
Maximum Input Power	650 W

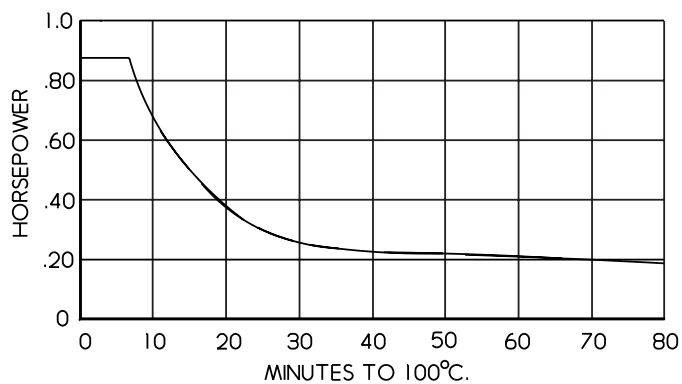

Figure 3-6 HD-700-1 Power Absorption Curve

HD-705-1

Shaft Diameter	0.4995 in / 0.5000 in (12.687 mm / 12.700 mm)
Shaft Height	5.875 in (149.2 mm)
Torque Ranges	200 oz·in 400 oz·in 800 oz·in
Input Inertia	1.101×10^{-3} lb·ft·s ²
Maximum Speed	10,000 rpm
Maximum Input Power	1400 W

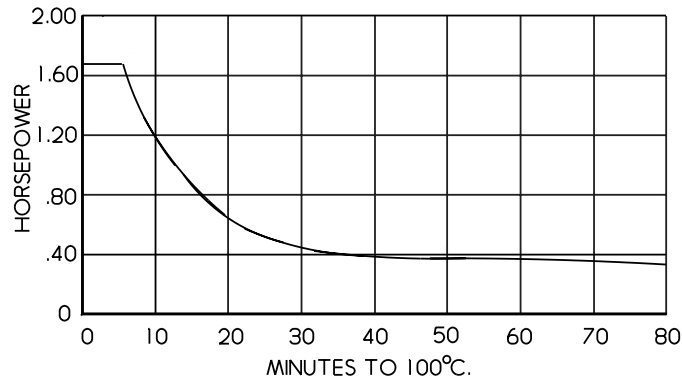

Figure 3-7 HD-705-1 Power Absorption Curve

3.4 FIXTURES AND COUPLINGS

When mounting the test motor, please consider the following:

- Construct precise fixtures that provide proper shaft alignment.
- Secure the test motor in the fixture to prevent torsional movement and bolt the fixture to the dynamometer base plate.
- Give consideration to the interaction of materials between the motor and test fixture. For example, a (magnetic) steel plate placed against the exposed lamination of an open frame motor can significantly influence performance. Some thin shell PM (permanent magnet) motors may be similarly affected.
- The dynamometer base plate material is an aluminum tool plate that is easily drilled and tapped. The use of helix thread inserts is a good idea if you are going to interchange fixtures often.



Note: For an additional charge, Magtrol can perform base plate modifications.

The following diagram illustrates examples of possible shaft misalignment.

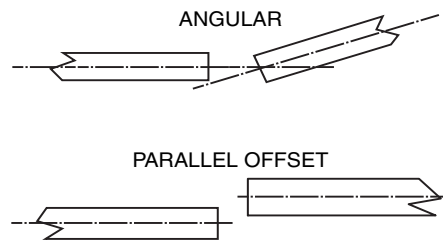

Figure 3–8 Examples of Possible Shaft Misalignment

The use of high quality double flexure couplings is recommended to help correct any misalignment problems. This type of coupling—two flexing elements separated by a solid link—inherently tolerates greater parallel offset. If you would like more specific coupling recommendations, contact Magtrol Technical Assistance. For precise misalignment tolerances, consult your coupling manufacturer.

3.5 WINDAGE

Although a smooth surface, the dynamometer rotor will drag air around with it. This air friction is tangential to the surface and impinges upon the stationary field assembly. The viscous drag that results then becomes part of the motor load and torque reading. However, there is a small amount of air dissipated as pumping loss. Since this appears as a load on the motor, not measured by the dynamometer, it becomes a source of error.

Windage effects on accuracy tests have been conducted on all Magtrol dynamometers. The percentage of torque loss due to windage ranges between 0.025% and 0.20% of full scale at maximum rated rpm. The larger percentage applies toward the smallest capacity dynamometer (HD-106). Because windage is proportional to the square of speed, it magnifies rapidly above rated speed. Conversely, at one half of the rated speed, the effect becomes immeasurably small.

3.6 FRICTION

Friction of the shaft bearings is a measurable load, but some friction can exist in the carrier bearing. When correctly loaded and lubricated, the friction is insignificant. The value may be quantitatively established by the following procedure.

1. Remove all attachments to the dynamometer shaft.
2. Swing the brake assembly up to full scale - by hand.
3. Carefully allow the assembly to return to zero without swinging back and forth.
4. Repeat steps 2 and 3—this time in the opposite direction—and note the reading.

The difference between zero and the second reading should be within the accuracy specifications listed in *Section 1.2 – Technical Specifications*. During actual motor testing there is usually enough system vibration to “settle” negating frictional effects. If excessive drag is present, mechanical realignment may be required, dependent upon dynamometer size. Certain mechanical factors need to be determined before corrective action proceeds. Please contact Magtrol Technical Assistance.

3.7 VIBRATION

All rotating dynamometer assemblies are precision balanced, however, the dynamometer shaft is cantilevered. This may cause vulnerability to radial forces.

At high speeds, some vibration and noise are inevitable but not necessarily harmful. However, excessive resonant vibrations, caused by bent shafts, poor alignment and out of balance couplings will produce excessive data errors and are a safety hazard.



WARNING! SHAFT COUPLINGS OPERATING AT SPEEDS ABOVE THEIR DESIGN LIMITS ARE EXTREMELY HAZARDOUS. MANY COUPLINGS CONTAIN SOMEWHAT LOOSELY SUPPORTED FLEXURE ELEMENTS. WHEN OVERDRIVEN, EXCESSIVE CENTRIFUGAL FORCE MAY DISPLACE THEM OUT OF AXIAL ALIGNMENT. AS THIS HAPPENS, THEY IMMEDIATELY BEGIN TO ABSORB ENERGY RESULTING IN SEVERE VIBRATION AND DESTRUCTION OF THE COUPLING.

3.8 COGGING

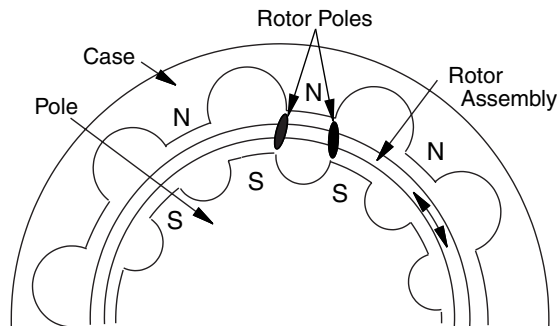

Figure 3-9 Hysteresis Brake Cross-Section

This cross-section shows (by one tooth) the magnetic relationship of the hysteresis brake elements. If the dynamometer shaft is at rest with torque applied, and if the torque control is then reduced to zero, a magnetic salient pole will be temporarily imposed on the rotor of the brake.

If the shaft is then rotated slowly, the magnetic poles on the rotor will attempt to align with the adjacent case-pole tooth form. This is often referred to as “cogging”. The action is sinusoidal—first it tries to resist rotation and then, as the rotor passes through the tooth form, it subsequently supports rotation. At a few hundred rpm, these forces integrate resulting in an effective torque of nearly zero.

To avoid magnetic cogging, before the shaft comes to rest, reduce the torque control to zero.

To remove cogging, once established, reapply current on the dynamometer. Then, decrease the current to zero while simultaneously rotating the dynamometer shaft.

3.9 EDDY CURRENTS

There is some Eddy current generation within the brake rotor. These magnetically induced currents cause an increase in brake torque proportional to speed.

The larger the hysteresis brake, the higher the rotor surface velocity. Additionally, as brakes become larger the rotor cross-sectional area increases. Each of these factors increase Eddy current generation. The combination results in speed-related torque increase, exhibiting a more pronounced effect on larger dynamometers.

On the smaller dynamometer sizes, 2% to 4%/1000 rpm is typical.

3.10 TEMPERATURE RISE

Temperature rise has a more complex effect on hysteresis brake load torque and is difficult to quantify. As the temperature of the brake increases, differential expansions cause dimensional changes that tend to increase torque. Conversely, electrical resistance in the rotor increases with temperature, resulting in decreased Eddy current generation and torque, all in a variable frame.

Where current and speed remain fixed, there may be a gradual torque increase over a period of a few moments. This will generally stabilize at 0.5% (for small dynamometers, up to HD-500-1) to 1.5% of the starting torque value, per 1000 rpm of applied speed.

4. Operating Principles

4.1 SPEED

The dynamometer is shipped with an internal speed pickup and two cords: one terminating with a 2-pin plug for the brake power, the other is a 14-pin plug servicing an optical encoder. This encoder consists of an infrared transmitter/receiver pair. On the end of the dynamometer shaft, positioned between the LED and detector, is an optical disc with opaque and clear segments. Rotation of the disc results in the detector generating a frequency of 60 pulses per shaft revolution.

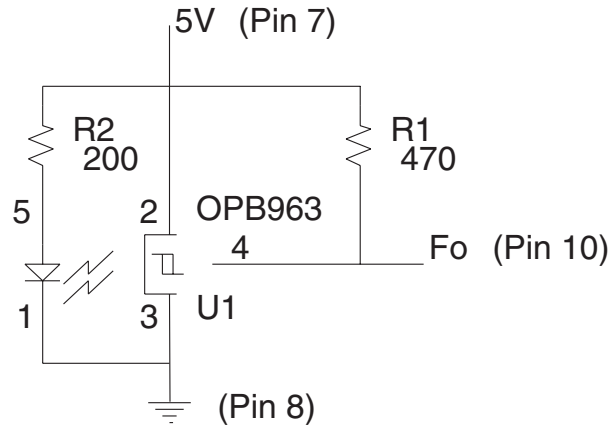

Figure 4-1 Optical Encoder Circuit

4.2 TORQUE

Torsional force, acting upon the hysteresis brake, is produced by the test motor, and applied to the brake's rotor-shaft assembly. Whatever torque exists on the rotor-shaft, must be reacted upon equally by the suspended brake-dial-weight assembly.

Since the brake assembly is imbalanced by the suspended weight attached to it, torsional force will lift the weight. The graduated dial provides a readout value equal to this torque. Once the weights are calibrated to match the dial graduations, the system accuracy becomes permanently fixed.

When torque is defined by a point on the radius of a weight, lifted in a circular motion, the scale derivation is inherently a cosine function - thus, the nonlinear scale graduations.

4.2.1 TORQUE STABILITY

A major advantage in using a hysteresis brake as a loading means, is the ability to produce torque essentially independent of speed. This permits very low speed and locked rotor torque testing.

Three factors have a minor secondary influence on hysteresis brake torque. They are:

- Hysteresis brake control current (*see Section 1.2.1*)
- Eddy current (*see Section 3.9*)
- Temperature rise (*see Section 3.10*)



Note: Torque changes as a result of these influences are always part of the actual torque measured—as applied to a test motor—and not errors.

5. Calibration

5.1 CALIBRATION PREPARATION

To check the torque calibration accuracy, it is necessary to apply a precisely known torque value. The most accurate method to apply a known torque is with the use of a beam and weight system. Various sizes of torque calibration beams and precision calibration weights are available from Magtrol.

The pin location on the torque beam precisely fixes the distance. Therefore, the force (weight) required will be equal to the torque value divided by the distance on the beam.

5.2 CALIBRATION PROCEDURE

1. Apply full torque to the dynamometer, until the shaft is restrained from rotating.
2. Install the calibration beam on the dynamometer shaft as shown in the following diagram. Lock the beam with the locking screw against the flat on the shaft. Do not hang the weight until instructed to do so in step 4.

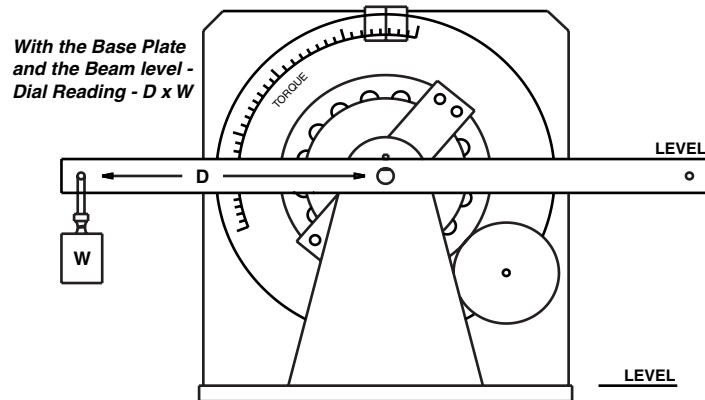

Figure 5-1 Calibration Setup



Note: The calibration beam must be maintained exactly level at all times.

3. Using lightweight (but strong) line, form a loop and attach it to the weight.



Note: Do not use a wire hook. Hooks will generally apply the force slightly off the center line of the pin.

4. Suspend a known weight, at a known distance, from the beam. See *Section 5.1 – Calibration Preparation*.
5. While preventing the beam from rotating, and maintaining it in a level position, lift the weight-dial assembly until a balance is attained between the assembly and the beam.
6. Observe the deviation, if any.
7. Remove the calibration beam.

The dynamometer is calibrated and ready for motor testing.



Testing, Measurement and Control of Torque-Speed-Power • Load-Force-Weight • Tension • Displacement

www.magtrol.com

MAGTROL INC

70 Gardenville Parkway
Buffalo, New York 14224 USA
Phone: +1 716 668 5555
Fax: +1 716 668 8705
E-mail: magtrol@magtrol.com

MAGTROL SA

Route de Montena 77
1728 Rossens/Fribourg, Switzerland
Phone: +41 (0)26 407 3000
Fax: +41 (0)26 407 3001
E-mail: magtrol@magtrol.ch

Subsidiaries in:

Great Britain
Germany • France
China • India

Worldwide Network
of Sales Agents

