

TSC 401 Torque/Speed Conditioner

1.0 CONNECTION

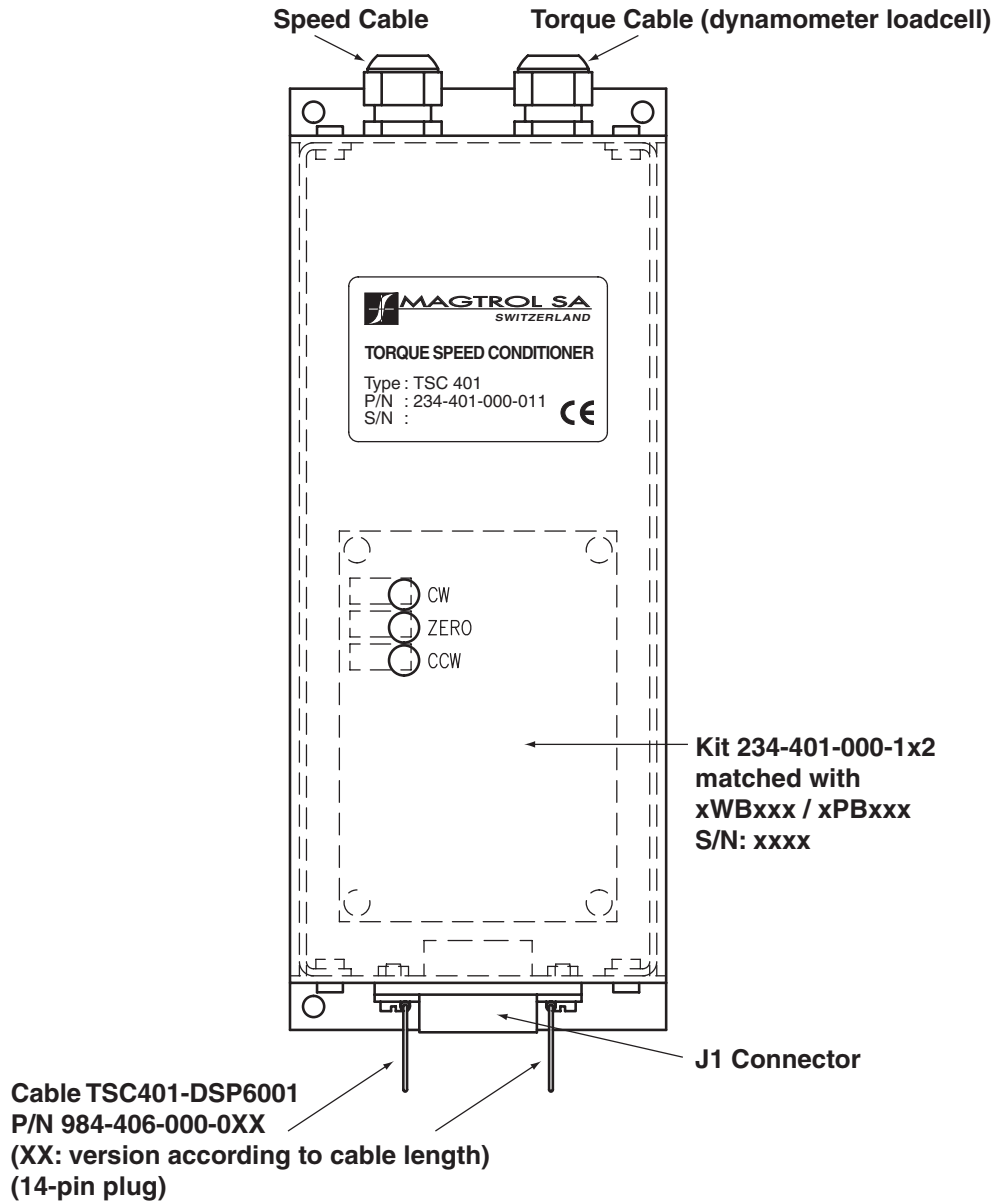
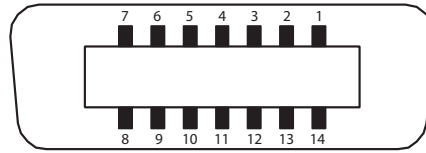

Figure 1. TSC 401 Connection

1.1 CABLES

WB / PB Dynamometer Model	KIT TSC401 + Cable	Torque Cable (dyno load cell)	Speed Cable
2.7 ; 43	234-401-000-112	944-121-000-011	944-122-000-011
65 ; 115 ; 15	234-401-000-122	944-123-000-011	944-124-000-011

1.2 EXTERNAL CONNECTOR



FOR TORQUE MEASURE

- 3. +24 VDC (yel)
- 4. ±24 VDC COM (yel/blk) (analog common)
- 5. ±24 VDC COM (yel/blk) (analog common)
- 6. -24 VDC (gy)

FOR SPEED MEASURE

- 7. +5 VDC (red)
- 8. +5.0 VDC COM (digital common)

Figure 2. J1 14-pin Connector

1.3 INTERNAL CONNECTORS (ON TSC 401 BOARD)

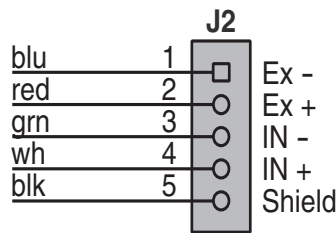

Figure 3. J2 Torque Connector (for Connection of Load Cell)

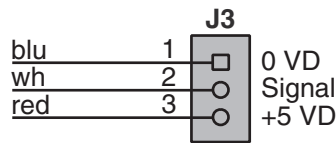

Figure 4. J3 60-bit Speed Connector

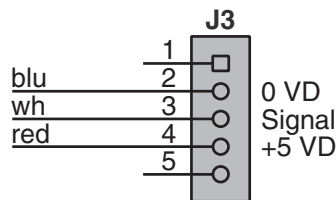

Figure 5. J3 600x-bit Speed Connector Speed (RI-58)

2.0 CONFIGURATION - SOLDER LINKS



Note: In the table below, the notation for instance 1–7 means that all the solder links from 1 through 7 are to be done.

Dynamometer Model	Nominal Torque	Loadcell Sensitivity (mV/V)	Signal Provided by the Load Cell (mV) [sensitivity × power supply (~ 10 VDC)]	Links to be Soldered
1 WB 2.7-8-K	150 mNm	0.65	0 – 6.5	1 – 7
2 WB 2.7-8-K	300 mNm	0.32	0 – 3.2	1 – 11
3 WB 2.7-8-K	450 mNm	0.48	0 – 4.8	1 – 9
4 WB 2.7-8-K	600 mNm	0.64	0 – 6.4	1 – 8
1 PB 2.7-8-K	600 mNm	0.64	0 – 6.4	1 – 8
2 PB 2.7-8-K	1.2 Nm	1.27	0 – 12.7	1 – 4
4 PB 2.7-8-K	2.4 Nm	1.07	0 – 10.7	1 – 5
1 WB 43	1.5 Nm	0.75	0 – 7.5	1 – 6
2 WB 43	3 Nm	0.75	0 – 7.5	1 – 6
1 PB 43	5 Nm	1.25	0 – 12.5	1 – 4
1 PB 43-S	5 Nm	0.63	0 – 6.3	1 – 7
2 PB 43	10 Nm	1.25	0 – 12.5	1 – 4
1 WB 65	10 Nm	0.95	0 – 9.5	1 – 5
1 WB 65-F	10 Nm	0.63	0 – 6.3	1 – 7
2 WB 65	20 Nm	1.26	0 – 12.6	1 – 4
2 WB 65-F	20 Nm	0.76	0 – 7.6	1 – 6
1 PB 65	25 Nm	1.58	0 – 15.8	1 – 3
2 PB 65	50 Nm	1.26	0 – 12.6	1 – 4
2 PB 65-S	50 Nm	0.63	0 – 6.3	1 – 7
2 PB 65-G	50 Nm	0.63	0 – 6.3	1 – 7
1 WB 115	50 Nm	1.06	0 – 10.6	1 – 5
2 WB 115	100 Nm	1.06	0 – 10.6	1 – 5
1 PB 115	100 Nm	1.06	0 – 10.6	1 – 5
1 PB 115-G	100 Nm	0.53	0 – 5.3	1 – 8
2 PB 115	200 Nm	1.06	0 – 10.6	1 – 5
1 WB 15	140 Nm	1.27	0 – 12.7	1 – 4
2 WB 15	280 Nm	2.54	0 – 25.4	1
3 WB 15	420 Nm	0.76	0 – 7.6	1 – 6
4 WB 15	560 Nm	1.02	0 – 10.2	1 – 5
1 PB 15	300 Nm	2.72	0 – 27.2	1
2 PB 15	600 Nm	1.1	0 – 11.0	1 – 5
4 PB 15	1200 Nm	1.1	0 – 11.0	1 – 5



Note: The values of tension of the cell can vary according to the mechanical and electrical tolerances. It is acceptable that solder links vary from ± 1 position with regard to the table above. If the dynamometer is not fitted with a standard Magtrol Load Cell, solder links have to be configured as per comparable load cell sensitivity in the above table. When delivered from the factory with a dynamometer, the TSC 401 will be configured and matched with the dynamometer prior to delivery and labeled accordingly.

3.0 CALIBRATION - TSC 401 WITH DYNAMOMETER

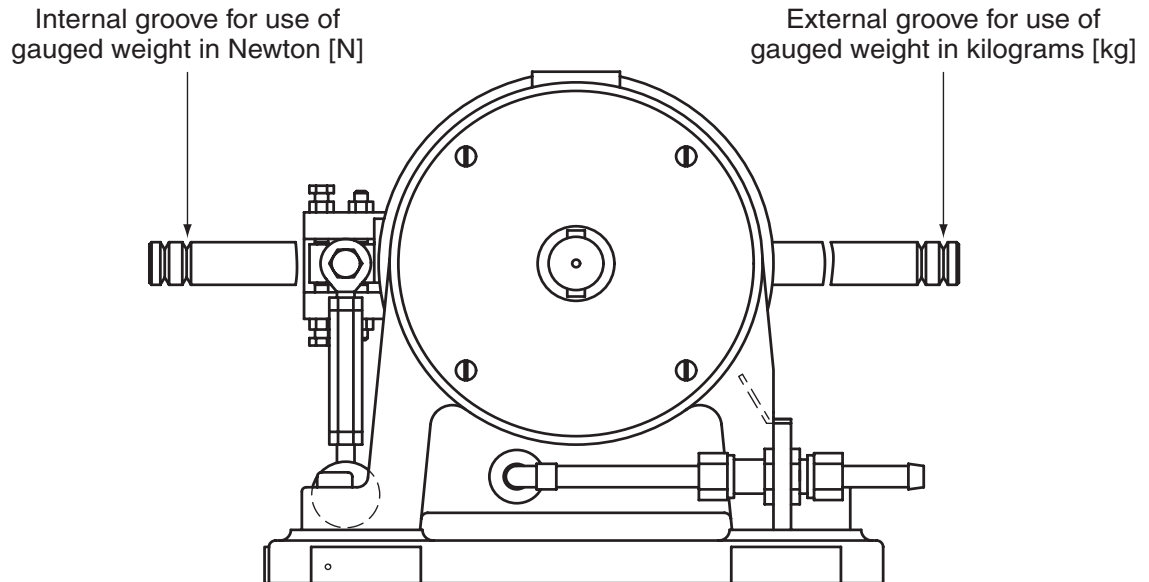

Figure 6. WB/PB Dynamometer with Calibration Arm

1. Make sure that the solder link configuration is completed according to the table in *Section 2.0*.
2. Connect the TSC 401 to the dynamometer and to the DSP6001 controller.
3. Mount both sides of the calibration arm according to *Figure 6*.
4. Connect a voltmeter (multimeter # 1) between TP3 (+) and TP4 (-). Signal provided by the TSC 401: 0 ± 5 VDC
5. Connect a voltmeter (multimeter # 2) between terminals 3 (IN-) and 4 (IN+) of connector J2. Signal provided by the load cell is according to the table in *Section 2.0 Configuration - Solder Links*.
6. Switch ON the DSP6001.
7. Configure the DSP6001 as follows:
 - Display Unit = Nm
 - Scale Factor = According to specifications of the dynamometer to be calibrated.
8. Adjust ZERO potentiometer until it reads 0 VDC (± 2 mV) (multimeter # 1).
Signal provided by the load cell should be: 0 mV (multimeter # 2)
9. Apply 100% of the nominal load on the positive side.
10. Check if the adjustment is possible from 4.75 VDC up to 5.25 VDC with CW.
If 4.75 VDC cannot be reached because it is not possible to decrease the signal to that value, one solder link should be removed. On the contrary, if 5.75 VDC cannot be reached by increasing the signal, one solder link should be added.
11. Adjust CW until it reads (#1) + 5.000 VDC (± 5 mV) (multimeter # 1). Signal provided by the load cell should be according to the table in *Section 2.0* (multimeter # 2).
Set the overload nut in order to make the signal decrease (+ 4.9 VDC)
12. Apply 200% of the nominal load and set the overload nut to + 7.5 VDC (± 100 mV) (multimeter # 1).

13. Unload to 100% and check if it still reads + 5.000 VDC (± 5 mV) (multimeter # 1).
14. Unload completely. The signal should be 0 VDC (± 10 mV) (multimeter # 1).
15. Apply 100% of the nominal load on the negative side.
16. Adjust **CCW** until it reads (#1) - 5.000 VDC (± 5 mV). Signal provided by the load cell should be according to the table in *Section 2.0* (multimeter # 2).
17. Set the overload nut in order to make the signal decrease (- 4.9 VDC)
18. Apply 200% of the nominal value and set the overload nut to - 7.5 V (± 100 mV).
19. Unload to 100% and check if it still reads - 5.000 V (± 5 mV).
20. Unload completely. It should read 0 V (± 10 mV).



Note: If the system does not include a DSP6001 Dynamometer Controller, connect the TSC 401 to the Power Supply according to the J1 connector pin set up (see *Figure 7*) and follow the above calibration procedure.

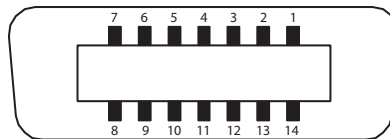

FOR TORQUE MEASURE

- 3. +24 VDC (yel)
- 4. ± 24 VDC COM (yel/blk) (analog common)
- 5. ± 24 VDC COM (yel/blk) (analog common)
- 6. -24 VDC (ay)

FOR SPEED MEASURE

- 7. +5 VDC (red)
- 8. +5.0 VDC COM (digital common)

Figure 7. J1 Connector for Calibration

REVISION HISTORY		
Date	Edition	Change
07/2003	First Edition, revision A	New layout - no change in content
09/2000	First Edition	Original manual



Testing, Measurement and Control of Torque-Speed-Power • Load-Force-Weight • Tension • Displacement

www.magtrol.com

MAGTROL INC
 70 Gardenville Parkway
 Buffalo, New York 14224 USA
 Phone: +1 716 668 5555
 Fax: +1 716 668 8705
 E-mail: magtrol@magtrol.com

MAGTROL SA
 Route de Montena 77
 1728 Rossens/Fribourg, Switzerland
 Phone: +41 (0)26 407 3000
 Fax: +41 (0)26 407 3001
 E-mail: magtrol@magtrol.ch

Subsidiaries in:
 Germany • France
 China • India
 Worldwide Network
 of Sales Agents

